



QZ(H)系列潜水轴流泵、混流泵

QZ(H) Series Submersible Axial Pump & Mixed Flow Pump



产品简介 Brief introduction

QZ系列潜水轴流泵、QH系列潜水混流泵是为大流量、较低扬程场合设计的，潜水轴流泵使用扬程一般在10米以下，潜水混流泵使用扬程在20米以内。本产品是传统轴流泵、混流泵的最佳换代产品，电机与水泵构成一体，潜入水中运行，具有传统机组无法比拟的一系列优点。

QZ series submersible axial pump and QH series submersible mixed-flow pump are designed for high-flow and low-head occasions. The service head of submersible axial pump is generally below 10 meters, and that of submersible mixed-flow pump is within 20 meters. This product is the best replacement of traditional axial pump and mixed flow pump. The motor and water pump are integrated and operate under the water. It has a number of advantages which are incomparable by traditional units.

型号说明

350 Q(H) - 70 G (D)

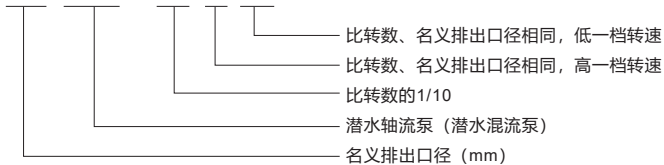

主要用途及特点 Main applications and features

主要用途:

Main applications:

在农业中，用于灌溉与排水；在市政中用于排雨水、轻度污水；在工业中用于工艺用水、冷却水及原水供应；在水利中用于调水工程，适宜用于输送清水或者轻度污水。

It is used for irrigation and drainage in agriculture field; used to discharge rainwater and mild sewage in municipal construction; used for supplying process water, cooling water and raw water; used for water diversion projects in water conservancy to transport clean water or mild sewage.

特点:

Main features:

1、由于电机与水泵构成一体，现场无需进行耗工、耗时、复杂的轴线对中装配程序，安装十分方便、快捷，因此可不预留备用泵的机位，将备用泵存于库房，节省泵站进水池的投资。由于潜入水中运行，可大大简化泵站的土建及建筑结构工程，减少安装面积，节约泵站总造价的30~40%。

Since the motor and the water pump are integrated, no labor-consuming, time-consuming and complicated axial alignment assembly procedures are required on site. The installation process is easy, so the spare pump can be stored in the warehouse without reserving the machine position for the spare pump, thus saving the investment in the intake tank of the pump station. The submerged operation can greatly simplify the civil and structural engineering of the pump station, reduce the installation area and save 30~40% of the total cost of the pump station.

2、泵在水中运行，水流从电机周围流过，噪声低，电机冷却条件好。可以建为地下泵站，保持地面的环境风貌。The pump runs under the water and the water flows around the motor so as to achieve a low noise and good cooling condition. An underground pump station can be constructed to maintain the environmental features of the ground.

3、采用潜水电泵，是解决在水位涨落大的沿江、湖泊地区建泵站和防洪问题最彻底的方法，省去了机泵间的长轴，提高了运行安全性。

The use of submersible motor-pump is the most thorough method to solve the problems of building pump stations and flood control in areas along rivers and lakes with large fluctuation of water level. It saves the long axis between pumps and improves the safety and reliability of operation.

Model description

350 Q(H) - 70 G (D)

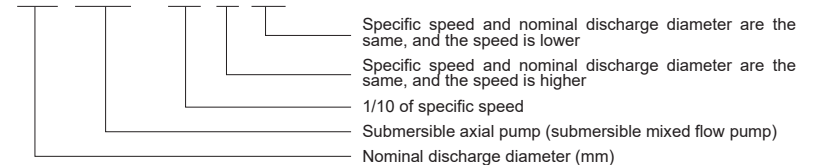

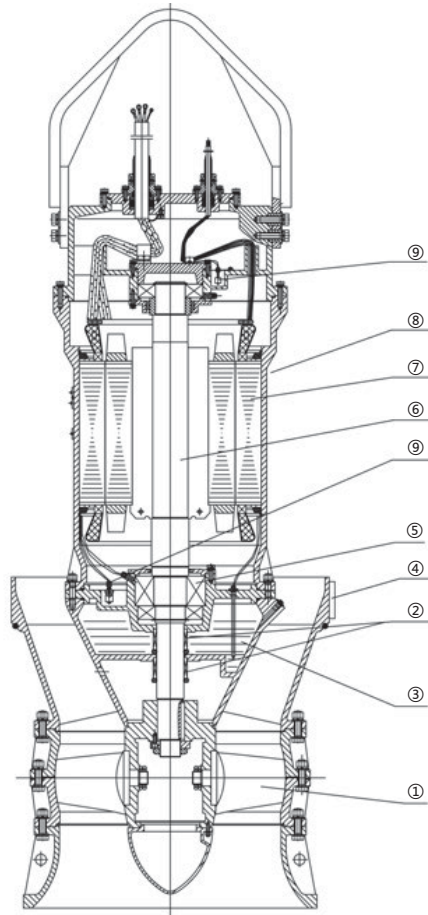

QZ型潜水轴流泵结构图
Structural drawing of QZ submersible axial pump

- 1、叶轮
Impeller
叶轮采用目前最先进的水力模型换算所得，性能优良、稳定、成熟。选择较小的nD值，抗汽蚀性能好，确保运行平稳。
The impeller is converted by the most advanced hydraulic model, and it has excellent, stable and mature performance. A small nD value is selected to ensure good cavitation resistance and smooth operation.
- 2、轴密封
Shaft seal
两套独立的机械密封，使电机与泵密封隔离；上下串联安装，提供多重保险，提高了可靠性。
Two sets of independent mechanical seals isolate the motor from the pump seal. Installation in series up and down provides multiple insurances and improves reliability.
- 3、油室
Oil chamber
油润滑并冷却密封，在电机与所输送的介质之间起到隔离作用。内留的体积可减缓油室内压力的升高。
Oil lubricates and cools the seal to isolate the motor from the medium being transported. The reserved volume can slow down the pressure rise in the oil chamber.
- 4、防转装置
Anti-rotating device
机组启动瞬间，电机启动力矩的反作用力矩，常常会使机组整体向相反方向旋转，防转装置能解决这个问题。
At the moment of starting the unit, the reaction torque of the starting torque of the motor often makes the whole unit rotate in the opposite direction. The anti-rotating device can solve this problem.
- 5、轴承
Bearing
轴承采用滚动轴承，能够承受所有的轴向和径向负荷，并完全与泵输送的介质分开。
The bearing adopts rolling bearing, which can bear all axial and radial loads and is completely separated from the medium delivered by the pump.
- 6、泵/电机轴
Pump/motor shaft
泵与电机同轴，结构紧凑，轴伸尽量缩短，从设计上减小挠度，运行时振动小，密封和轴承寿命更长。
The pump is coaxial with the motor for compact structure and shortened shaft extension. This design can reduce the deflection and vibration during the operation, so as to guarantee a longer service life of seal and bearing.
- 7、电机
Motor
高性能鼠笼式感应电机，特别为潜水
High-performance squirrel cage induction motor is especially designed and manufactured in accordance with GB755 standard. The pump is designed with an insulation class F. The highest working temperature can reach 135℃.
- 8、冷却
Cooling
电机外壳直接将热量传到周围介质中，热量被周围的水流带走。大功率高中压电机，采用内风道散热专利技术，使得三相绕组温升低、温度场分布均匀。
The motor casing directly transfers heat to the surrounding medium, and the heat is carried away by the surrounding water flow. Large-power high-medium voltage motor adopts patented technology of internal air duct heat dissipation, which makes the temperature rise of three-phase winding low and the temperature field evenly distributed.
- 9、监测装置
Monitoring device
潜水泵装有多道保护装置，可把引线引至电控箱。保护装置有：过载、缺相、泄露、超温、湿度、浸水保护等（视泵的结构不同而有差别）。
The submersible pump is equipped with multiple protection devices, which can lead the lead to the electric cabinet. The protection devices include overload protection, open-phase protection, leakage protection, over-temperature protection, humidity protection, and immersion protection (varied according to the pump structure).

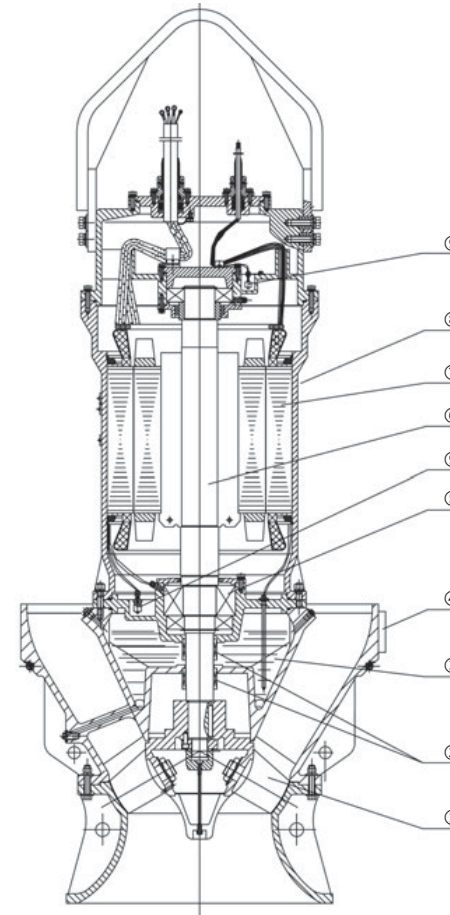

QH型潜水混流泵结构图
Structural drawing of QH submersible mixed flow pump

- 1、叶轮
Impeller
叶轮采用目前最先进的水力模型换算所得，性能优良、稳定、成熟。选择较小的nD值，抗汽蚀性能好，确保运行平稳。
The impeller is converted by the most advanced hydraulic model, and it has excellent, stable and mature performance. A small nD value is selected to ensure good cavitation resistance and smooth operation.
- 2、轴密封
Shaft seal
两套独立的机械密封，使电机与泵密封隔离；上下串联安装，提供多重保险，提高了可靠性。
Two sets of independent mechanical seals isolate the motor from the pump seal. Installation in series up and down provides multiple insurances and improves reliability.
- 3、油室
Oil chamber
油润滑并冷却密封，在电机与所输送的介质之间起到隔离作用。内留的体积可减缓油室内压力的升高。
Oil lubricates and cools the seal to isolate the motor from the medium being transported. The reserved volume can slow down the pressure rise in the oil chamber.
- 4、防转装置
Anti-rotating device
机组启动瞬间，电机启动力矩的反作用力矩，常常会使机组整体向相反方向旋转，防转装置能解决这个问题。
At the moment of starting the unit, the reaction torque of the starting torque of the motor often makes the whole unit rotate in the opposite direction. The anti-rotating device can solve this problem.
- 5、轴承
Bearing
轴承采用滚动轴承，能够承受所有的轴向和径向负荷，并完全与泵输送的介质分开。
The bearing adopts rolling bearing, which can bear all axial and radial loads and is completely separated from the medium delivered by the pump.
- 6、泵/电机轴
Pump/motor shaft
泵与电机同轴，结构紧凑，轴伸尽量缩短，从设计上减小挠度，运行时振动小，密封和轴承寿命更长。
The pump is coaxial with the motor for compact structure and shortened shaft extension. This design can reduce the deflection and vibration during the operation, so as to guarantee a longer service life of seal and bearing.
- 7、电机
Motor
高性能鼠笼式感应电机，特别为潜水
High-performance squirrel cage induction motor is especially designed and manufactured in accordance with GB755 standard. The pump is designed with an insulation class F. The highest working temperature can reach 135℃.
- 8、冷却
Cooling
电机外壳直接将热量传到周围介质中，热量被周围的水流带走。大功率高中压电机，采用内风道散热专利技术，使得三相绕组温升低、温度场分布均匀。
The motor casing directly transfers heat to the surrounding medium, and the heat is carried away by the surrounding water flow. Large-power high-medium voltage motor adopts patented technology of internal air duct heat dissipation, which makes the temperature rise of three-phase winding low and the temperature field evenly distributed.
- 9、监测装置
Monitoring device
潜水泵装有多道保护装置，可把引线引至电控箱。保护装置有：过载、缺相、泄露、超温、湿度、浸水保护等（视泵的结构不同而有差别）。
The submersible pump is equipped with multiple protection devices, which can lead the lead to the electric cabinet. The protection devices include overload protection, open-phase protection, leakage protection, over-temperature protection, humidity protection, and immersion protection (varied according to the pump structure).

性能曲线与参数 Performance curves and parameters

350QZ-70G

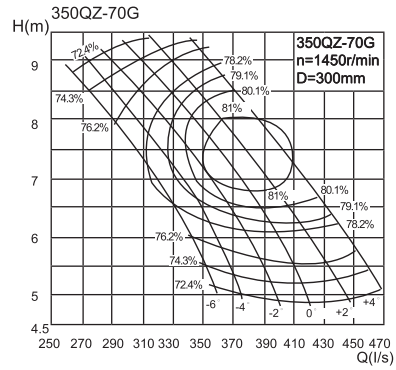

叶片安装角度 Blade angle	流量 Flow Q		扬程 Head H (m)	转速 Speed n (r/min)	功率 Power P (kW)		重量 weight (kg)	效率 Efficiency η (%)	叶轮直径 Impeller diameter (mm)
	(m³/h)	l/s			轴功率 Shaft power	电机功率 Motor power			
-6°	1008.0	280.0	8.2	1450	29.2	37	540	77.0	300
	1119.6	311.0	7.1		27.4	79.0			
	1198.8	333.0	6.2		25.9	78.0			
-4°	1044.0	290.0	8.5	1450	31.3	45	560	77.0	300
	1172.2	325.6	7.2		28.7			80.0	
	1267.2	352.0	6.2		27.4			78.0	
-2°	1090.8	303.0	8.5	1450	32.8	45	560	77.0	300
	1209.6	336.0	7.5		30.5			81.0	
	1346.4	374.0	6.2		28.7			79.0	
0°	1152.0	320.0	8.6	1450	34.5	45	560	78.0	300
	1299.6	361.0	7.3		31.5			82.0	
	1411.2	392.0	6.2		30.1			79.0	
+2°	1198.8	333.0	8.7	1450	35.5	45	560	80.0	300
	1342.8	373.0	7.7		34.3			82.0	
	1479.6	411.0	6.2		31.6			79.0	
+4°	1242.0	345.0	9.2	1450	40.4	45	560	77.0	300
	1368.0	380.0	8.0		36.8			81.0	
	1569.6	436.0	6.3		34.5			78.0	

350QZ-100

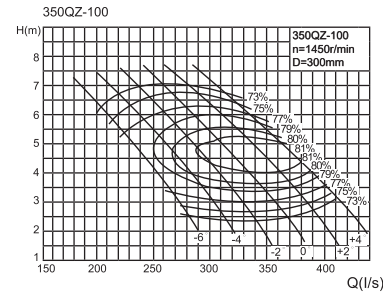

叶片安装角度 Blade angle	流量 Flow Q		扬程 Head H (m)	转速 Speed n (r/min)	功率 Power P (kW)		重量 weight (kg)	效率 Efficiency η (%)	叶轮直径 Impeller diameter (mm)
	(m³/h)	l/s			轴功率 Shaft power	电机功率 Motor power			
-6°	826.2	229.5	5.2	1450	15.2	18.5	490	77.0	300
	900.0	250.0	4.0		12.4	79.0			
	969.8	269.4	3.2		11.0	77.0			
-4°	877.1	243.6	5.8	1450	18.0	22	500	77.0	300
	1008.0	280.0	4.1		14.0			80.1	
	1100.8	305.8	2.9		11.3			77.0	
-2°	938.8	260.8	6.1	1450	20.2	22	500	77.0	300
	1098.0	305.0	4.2		15.5			80.7	
	1198.2	332.8	2.9		12.3			77.0	
0°	1005.8	279.4	6.2	1450	22.0	22	500	77.0	300
	1188.0	330.0	4.2		16.8			81.0	
	1284.3	356.8	2.9		13.2			77.0	
+2°	1098.2	305.1	6.3	1450	24.4	30	525	77.0	300
	1260.0	350.0	4.4		18.5			81.5	
	1360.1	377.8	3.2		15.4			77.0	
+4°	1200.4	333.4	6.0	1450	25.4	30	525	77.0	300
	1350.0	375.0	4.4		19.9			81.2	
	1432.2	397.8	3.5		17.7			77.0	

350QZ-70D

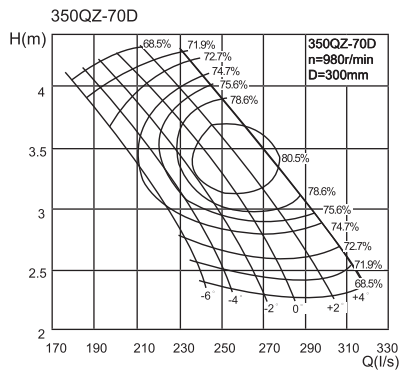

叶片安装角度 Blade angle	流量 Flow Q		扬程 Head H (m)	转速 Speed n (r/min)	功率 Power P (kW)		重量 weight (kg)	效率 Efficiency η (%)	叶轮直径 Impeller diameter (mm)
	(m³/h)	l/s			轴功率 Shaft power	电机功率 Motor power			
-6°	681.4	189.3	3.7	980	9.4	11	450	73.5	300
	756.8	210.2	3.2		8.8	75.5			
	810.4	225.1	2.8		8.4	74.5			
-4°	705.7	196.0	3.9	980	10.1	15	480	73.5	300
	792.4	220.1	3.3		9.3			76.5	
	856.6	238.0	2.8		8.9			74.5	
-2°	737.4	204.8	3.9	980	10.6	15	480	73.5	300
	817.7	227.1	3.4		9.8			77.5	
	910.2	252.8	2.8		9.3			75.5	
0°	778.8	216.3	3.9	980	11.2	15	480	74.5	300
	878.5	244.0	3.3		10.2			78.5	
	954.0	265.0	2.8		9.7			75.5	
+2°	810.4	225.1	4.0	980	11.5	15	480	76.5	300
	907.7	252.1	3.5		11.1			78.5	
	1000.2	277.8	2.8		10.2			75.5	
+4°	839.6	233.2	4.2	980	13.1	15	480	73.5	300
	924.8	256.9	3.7		11.9			77.5	
	1061.0	294.7	2.9		11.2			74.5	

350QZ-130

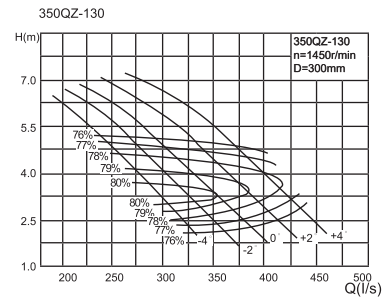

叶片安装角度 Blade angle	流量 Flow Q		扬程 Head H (m)	转速 Speed n (r/min)	功率 Power P (kW)		重量 weight (kg)	效率 Efficiency η (%)	叶轮直径 Impeller diameter (mm)
	(m³/h)	l/s			轴功率 Shaft power	电机功率 Motor power			
-4°	864.4	240.1	5.2	1450	16.1	18.5	460	76.0	300
	1116.7	310.2	2.9		10.9	80.8			
	1196.9	332.5	2.1		9.0	76.0			
-2°	964.2	267.8	5.2	1450	17.9	22	480	76.0	300
	1200.6	333.5	3.1		12.6			80.5	
	1300.2	361.2	2.2		10.2			76.0	
0°	1064.7	295.8	5.1	1450	19.4	22	480	76.0	300
	1280.2	355.6	3.2		13.9			80.1	
	1390.3	386.2	2.2		10.9			76.0	
+2°	1211.7	336.6	4.8	1450	20.8	30	495	76.0	300
	1379.2	383.1	3.4		16.1			79.3	
	1484.9	412.5	2.5		13.3			76.0	
+4°	1334.4	370.7	4.8	1450	22.9	30	495	76.0	300
	1476.4	410.1	3.5		17.9			78.5	
	1563.6	434.3	2.8		15.7			76.0	

500QZ-70

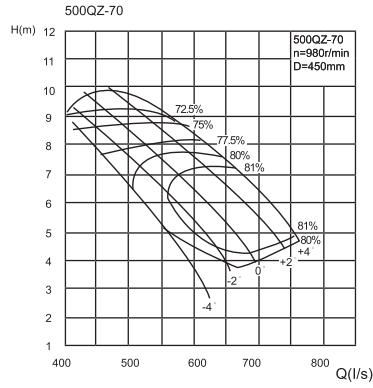

叶片安装角度 Blade angle	流量 Flow Q		扬程 Head H (m)	转速 Speed n (r/min)	功率 Power P (kW)		重量 weight (kg)	效率 Efficiency η (%)	叶轮直径 impeller diameter (mm)
	(m³/h)	l/s			轴功率 Shaft power	电机功率 Motor power			
-4°	1368.0	380.0	9.4	980	50.0	70.0	860	70.0	450
	1760.0	488.9	7.0		42.1	79.6			
	2060.0	572.2	4.3		30.7	78.5			
-2°	1720.0	477.8	8.2	51.5	74.5	79.8	81.2	450	
	2010.0	558.3	6.4	43.7	80.0	80.0			
	2250.0	625.0	4.9	40.8	73.5	79.8			
0°	2099.0	583.1	7.0	50.1	79.8	81.2	860	450	
	2160.0	600.0	6.3	45.6	77.0	81.5			
	2510.0	697.2	3.9	34.6	77.0	81.5			
+2°	2340.0	650.0	6.6	51.5	81.5	83.0	860	450	
	2560.0	711.1	5.5	46.7	82.0	81.5			
	2660.0	738.9	4.6	40.8	81.5	83.0			
+4°	2520.0	700.0	6.2	51.8	82.1	83.0	860	450	
	2592.0	720.0	6.0	51.0	83.0	83.0			
	2844.0	790.0	4.7	45.9	76.0	83.0			

500QZ-100D

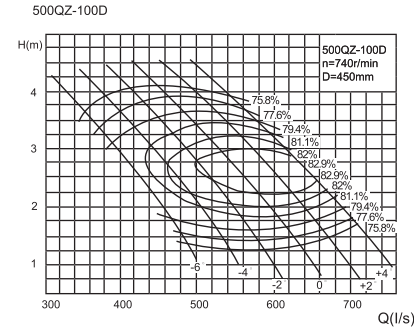

叶片安装角度 Blade angle	流量 Flow Q		扬程 Head H (m)	转速 Speed n (r/min)	功率 Power P (kW)		重量 weight (kg)	效率 Efficiency η (%)	叶轮直径 impeller diameter (mm)
	(m³/h)	l/s			轴功率 Shaft power	电机功率 Motor power			
-6°	1422.7	395.2	3.0	740	15.2	18.5	760	77.6	450
	1549.8	430.5	2.3		12.4	17.6			
	1670.0	463.9	1.9		11.0	17.6			
-4°	1510.4	419.6	3.4	18.0	22.0	22.0	790	77.6	450
	1735.8	482.2	2.4	14.1	20.3	20.3			
	1895.6	526.5	1.7	11.3	17.6	17.6			
-2°	1616.6	449.1	3.6	20.3	25.5	25.5	790	77.6	450
	1890.8	525.2	2.5	15.6	22.3	22.3			
	2063.3	573.1	1.7	12.3	17.6	17.6			
0°	1732.0	481.1	3.6	22.1	26.8	26.8	790	77.6	450
	2045.7	568.3	2.5	16.8	23.2	23.2			
	2211.3	614.3	1.7	13.2	17.6	17.6			
+2°	1891.1	525.3	3.7	24.5	30.0	30.0	830	77.6	450
	2169.7	602.7	2.6	18.5	25.5	25.5			
	2342.1	650.6	1.9	15.4	22.3	22.3			
+4°	2067.1	574.2	3.5	25.5	30.0	30.0	830	77.6	450
	2324.7	645.8	2.6	19.9	27.6	27.6			
	2466.2	685.1	2.1	17.7	22.3	22.3			

500QZ-100G

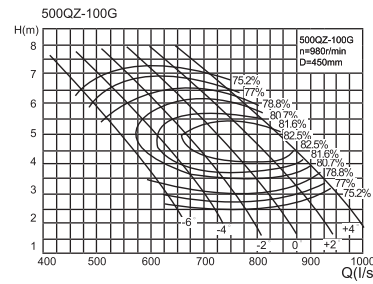

叶片安装角度 Blade angle	流量 Flow Q		扬程 Head H (m)	转速 Speed n (r/min)	功率 Power P (kW)		重量 weight (kg)	效率 Efficiency η (%)	叶轮直径 impeller diameter (mm)
	(m³/h)	l/s			轴功率 Shaft power	电机功率 Motor power			
-6°	1883.7	523.3	5.3	980	34.8	45	850	78.8	450
	2052.0	570.0	4.1		28.4	80.8			
	2211.1	614.2	3.3		25.1	78.8			
-4°	2000.6	555.7	6.0	41.2	78.8	81.9	870	450	
	2298.2	638.4	4.2	32.2	78.8	78.8			
	2509.8	697.2	3.0	25.8	78.8	78.8			
-2°	2140.5	594.6	6.3	46.3	78.8	82.5	870	450	
	2503.4	695.4	4.3	35.6	82.5	82.5			
	2731.9	758.9	3.0	28.1	78.8	78.8			
0°	2293.2	637.0	6.4	50.5	78.8	82.8	900	450	
	2708.6	752.4	4.3	38.4	82.8	82.8			
	2928.2	813.4	3.0	30.1	78.8	78.8			
+2°	2503.9	695.5	6.5	56.0	78.8	83.3	900	450	
	2872.8	798.0	4.5	42.4	83.3	83.3			
	3101.0	861.4	3.3	35.2	78.8	78.8			
+4°	2736.9	760.3	6.3	58.3	78.8	83.0	900	450	
	3078.0	855.0	4.5	45.6	83.0	83.0			
	3265.4	907.1	3.6	40.6	78.8	78.8			

500QZ-130G

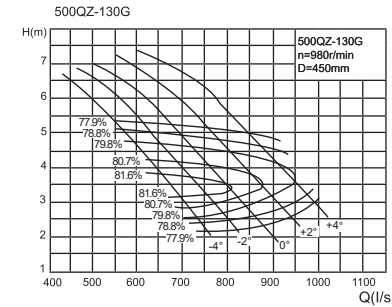

叶片安装角度 Blade angle	流量 Flow Q		扬程 Head H (m)	转速 Speed n (r/min)	功率 Power P (kW)		重量 weight (kg)	效率 Efficiency η (%)	叶轮直径 impeller diameter (mm)
	(m³/h)	l/s			轴功率 Shaft power	电机功率 Motor power			
-4°	1971.7	547.7	5.3	980	36.8	45	860	77.9	450
	2547.2	707.6	3.0		25.0	82.7			
	2730.1	758.4	2.2		20.6	77.9			
-2°	2199.3	610.9	5.3	41.0	77.9	77.9	900	450	
	2738.6	760.7	3.2	28.8	82.4	82.4			
	2965.8	823.8	2.3	23.4	77.9	77.9			
0°	2428.6	674.6	5.2	44.4	77.9	77.9	900	450	
	2920.1	811.1	3.3	31.9	82.0	82.0			
	3171.3	880.9	2.3	25.0	77.9	77.9			
+2°	2763.9	767.7	4.9	47.6	77.9	77.9	900	450	
	3146.0	873.9	3.5	36.8	81.2	81.2			
	3387.1	940.8	2.6	30.4	77.9	77.9			
+4°	3043.8	845.5	4.9	52.4	77.9	77.9	950	450	
	3367.7	935.5	3.6	41.0	80.4	80.4			
	3566.6	990.7	2.9	35.8	77.9	77.9			

500QZ-130D

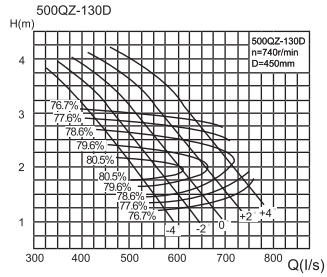

叶片安装角度 Blade angle	流量 Flow Q		扬程 Head H	转速 Speed n	功率 Power P (kW)		重量 weight	效率 Efficiency η	叶轮直径 Impeller diameter
	(m³/h)	l/s	(m)	(r/min)	轴功率 Shaft power	电机功率 Motor power	(kg)	(%)	(mm)
-4°	1488.5	413.5	3.0	740	16.1	76.7	750	76.7	450
	1923.0	534.2	1.7		10.9	18.5		81.5	
	2061.1	572.5	1.2		9.0	76.7			
-2°	1660.4	461.2	3.0		17.9	76.7	780	76.7	
	2067.4	574.3	1.8		12.6	81.2			
	2238.9	621.9	1.3		10.2	78.7			
0°	1833.4	509.3	3.0		19.4	76.7	830	76.7	
	2204.5	612.4	1.9		13.9	80.8			
	2394.1	665.0	1.3		10.9	76.7			
+2°	2086.5	579.6	2.8		20.8	76.7	830	76.7	
	2375.0	659.7	2.0		16.1	80.0			
	2557.0	710.3	1.5		13.3	76.7			
+4°	2297.8	638.3	2.8	22.9	76.7	830	76.7		
	2542.4	706.2	2.1	17.9	79.2				
	2692.5	747.9	1.6	15.7	76.7				

600QZ-100

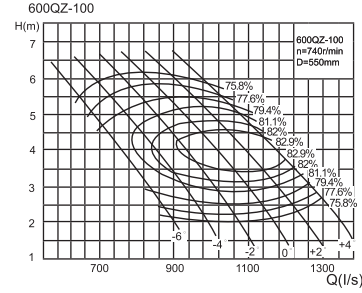

叶片安装角度 Blade angle	流量 Flow Q		扬程 Head H	转速 Speed n	功率 Power P (kW)		重量 weight	效率 Efficiency η	叶轮直径 Impeller diameter
	(m³/h)	l/s	(m)	(r/min)	轴功率 Shaft power	电机功率 Motor power	(kg)	(%)	(mm)
-6°	2598.4	721.8	4.6	740	40.5	79.4	1210	79.4	550
	2830.5	786.3	3.5		33.1	45		81.4	
	3050.0	847.2	2.8		29.3	79.4			
-4°	2758.5	766.2	5.1		48.0	79.4	1250	79.4	
	3170.2	880.6	3.6		37.5	55		82.5	
	3462.0	961.7	2.5		30.1	79.4			
-2°	2952.5	820.1	5.3		54.0	79.4	1320	79.4	
	3453.2	959.2	3.7		41.5	83.1			
	3768.3	1046.8	2.5		32.8	79.4			
0°	3163.2	878.7	5.4		58.8	79.4	1320	79.4	
	3736.3	1037.9	3.7		44.8	83.4			
	4039.2	1122.0	2.5		35.1	79.4			
+2°	3453.8	959.4	5.5	65.2	79.4	1320	79.4		
	3962.7	1100.8	3.9	49.5	83.9				
	4277.5	1188.2	2.8	41.0	79.4				
+4°	3775.3	1048.7	5.3	67.9	79.4	1320	79.4		
	4245.8	1179.4	3.9	53.2	83.6				
	4504.3	1251.2	3.1	47.3	79.4				

600QZ-70

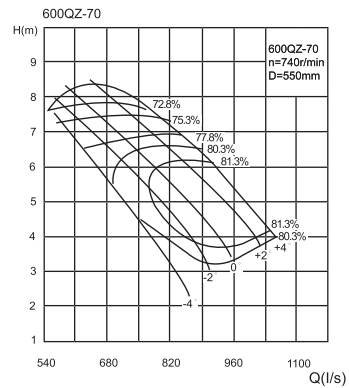

叶片安装角度 Blade angle	流量 Flow Q		扬程 Head H	转速 Speed n	功率 Power P (kW)		重量 weight	效率 Efficiency η	叶轮直径 Impeller diameter
	(m³/h)	l/s	(m)	(r/min)	轴功率 Shaft power	电机功率 Motor power	(kg)	(%)	(mm)
-4°	1886.5	524.0	8.0	740	58.5	70.3	1350	70.3	550
	2427.0	674.2	6.0		49.3	79.9			
	2840.7	789.1	3.7		35.9	78.8			
-2°	2371.9	658.9	7.0		60.3	74.8	1350	74.8	
	2771.8	769.9	5.5		51.2	80.3			
	3102.8	861.9	4.2		47.7	73.8			
0°	2894.5	804.0	6.0		58.6	80.1	1350	80.1	
	2978.6	827.4	5.4		53.4	81.5			
	3461.3	961.5	3.3		40.5	77.3			
+2°	3226.9	896.4	5.6		60.3	81.8	1350	81.8	
	3530.2	980.6	4.7		54.7	82.3			
	3668.1	1018.9	3.9		47.8	81.8			
+4°	3475.1	965.3	5.3	53.7	82.4	1350	82.4		
	3574.4	992.9	5.1	60.6	83.3				
	3921.9	1089.4	4.0	59.7	79.5				

600QZ-130

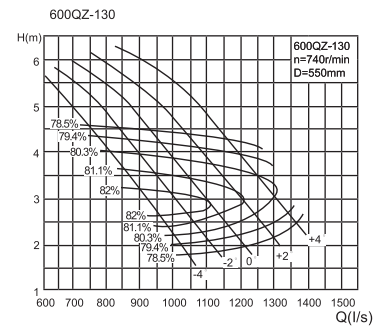

叶片安装角度 Blade angle	流量 Flow Q		扬程 Head H	转速 Speed n	功率 Power P (kW)		重量 weight	效率 Efficiency η	叶轮直径 Impeller diameter
	(m³/h)	l/s	(m)	(r/min)	轴功率 Shaft power	电机功率 Motor power	(kg)	(%)	(mm)
-4°	2718.5	755.1	4.6	740	42.9	78.5	1320	78.5	550
	3512.0	975.6	2.5		29.1	83.3			
	3764.3	1045.6	1.8		24.0	78.5			
-2°	3032.4	842.3	4.6		47.8	78.5	1320	78.5	
	3775.9	1048.9	2.7		33.6	83.0			
	4089.1	1135.9	1.9		27.3	78.5			
0°	3348.5	930.1	4.5		51.8	78.5	1320	78.5	
	4026.2	1118.4	2.8		37.1	82.6			
	4372.5	1214.6	1.9		29.2	78.5			
+2°	3710.8	1058.6	4.2		55.5	78.5	1400	78.5	
	4337.6	1204.9	3.0		42.9	81.8			
	4670.0	1297.2	2.2		35.4	78.5			
+4°	4196.7	1165.7	4.2	61.1	78.5	1400	78.5		
	4643.3	1289.8	3.1	47.8	81.0				
	4917.5	1366.0	2.5	41.7	78.5				

600QZ-160

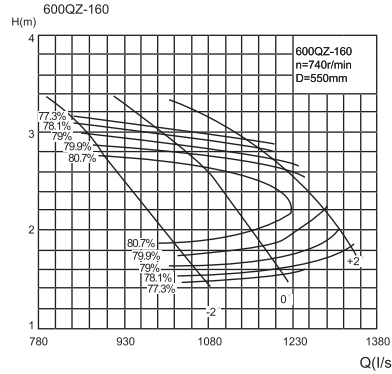

叶片安装角度 Blade angle	流量 Flow Q		扬程 Head H (m)	转速 Speed n (r/min)	功率 Power P (kW)		重量 weight (kg)	效率 Efficiency η (%)	叶轮直径 Impeller diameter (mm)
	(m³/h)	l/s			轴功率 Shaft power	电机功率 Motor power			
-2°	3072.5	853.5	3.0	740	32.4	37	1380	78.1	550
	3508.4	947.6	2.2		25.4			82.0	
0°	3832.5	1064.6	1.5		20.2	45	1420	78.1	
	3629.2	1008.1	2.9		37.2			78.1	
+2°	4074.3	1131.8	2.2		29.8	45	1420	81.2	
	4331.5	1203.2	1.6		24.1			78.1	
+2°	4215.0	1170.8	2.8		40.7			78.1	
	4549.6	1263.8	2.4		36.4			79.9	
+2°	4799.8	1333.3	1.8		30.9			78.1	

700QZ-70D

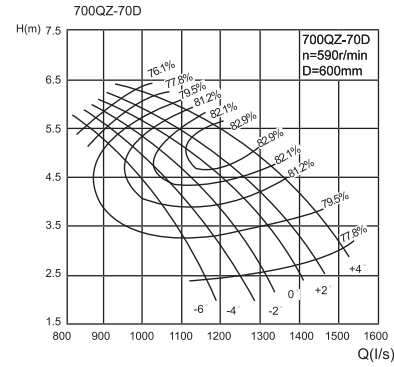

叶片安装角度 Blade angle	流量 Flow Q		扬程 Head H (m)	转速 Speed n (r/min)	功率 Power P (kW)		重量 weight (kg)	效率 Efficiency η (%)	叶轮直径 Impeller diameter (mm)
	(m³/h)	l/s			轴功率 Shaft power	电机功率 Motor power			
-6°	3213.5	892.6	5.3	590	58.9	75	2250	78.3	600
	3600.8	1000.2	4.5		53.6			81.3	
	3859.1	1072.0	3.7		48.2			80.3	
-4°	3351.2	930.9	5.3		61.3	90	2360	79.5	
	3773.0	1048.1	4.5		56.3			82.3	
	4068.5	1130.1	3.8		51.1			81.2	
-2°	3500.4	972.3	5.5		65.3	90	2360	79.8	
	3902.1	1083.9	4.8		62.3			82.3	
	4303.8	1195.5	3.8		55.6			80.3	
0°	3701.3	1028.1	5.5		68.9	90	2360	80.8	
	4160.3	1155.7	4.8	65.7	83.3				
	4533.3	1259.3	3.9	59.2	80.8				
+2°	3844.7	1068.0	5.6	73.3	90	2360	79.8		
	4289.5	1191.5	4.9	68.6			83.3		
	4748.5	1319.0	3.8	61.4			80.3		
+2°	3988.2	1107.8	5.9	78.2	90	2360	81.2		
	4389.9	1219.4	5.4	77.5			83.3		
	5021.1	1394.8	3.9	67.1			80.3		

700QZ-70G

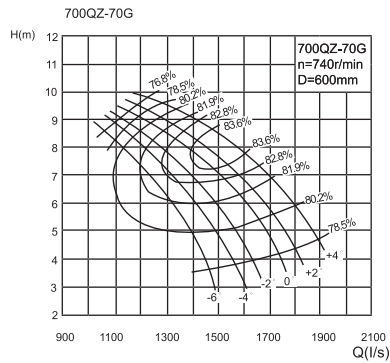

叶片安装角度 Blade angle	流量 Flow Q		扬程 Head H (m)	转速 Speed n (r/min)	功率 Power P (kW)		重量 weight (kg)	效率 Efficiency η (%)	叶轮直径 Impeller diameter (mm)
	(m³/h)	l/s			轴功率 Shaft power	电机功率 Motor power			
-6°	4032.0	1120.0	8.3	740	115.2	160	2350	79.0	600
	4518.0	1255.0	7.0		104.9			82.0	
	4842.0	1345.0	5.8		94.3			81.0	
-4°	4204.8	1168.0	8.4		119.8	185	2430	80.2	
	4734.0	1315.0	7.1		110.1			83.0	
	5104.8	1418.0	5.9		100.0			81.9	
-2°	4392.0	1220.0	8.6		127.6	185	2430	80.5	
	4896.0	1360.0	7.6		121.9			83.0	
	5400.0	1500.0	6.0		108.8			81.0	
0°	4644.0	1290.0	8.7		134.8	185	2430	81.5	
	5220.0	1450.0	7.6	128.5	84.0				
	5688.0	1580.0	6.1	115.8	81.5				
+2°	4824.0	1340.0	8.8	143.4	185	2430	80.5		
	5382.0	1495.0	7.7	134.2			84.0		
	5958.0	1655.0	6.0	120.0			81.0		
+4°	5004.0	1390.0	9.2	152.9	185	2430	81.9		
	5508.0	1530.0	8.5	151.6			84.0		
	6300.0	1750.0	6.2	131.2			81.0		

700QZ-100

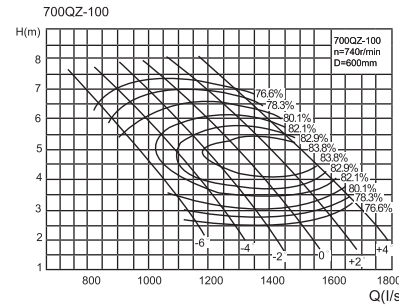

叶片安装角度 Blade angle	流量 Flow Q		扬程 Head H (m)	转速 Speed n (r/min)	功率 Power P (kW)		重量 weight (kg)	效率 Efficiency η (%)	叶轮直径 Impeller diameter (mm)
	(m³/h)	l/s			轴功率 Shaft power	电机功率 Motor power			
-6°	3373.4	937.0	5.4	740	62.1	75	2050	80.1	600
	3674.7	1020.8	4.2		50.7			82.1	
	3959.7	1099.9	3.3		44.8			80.1	
-4°	3581.2	994.8	6.0		73.5	90	2180	80.1	
	4115.7	1143.2	4.3		57.5			83.2	
	4494.6	1248.5	3.0		46.1			80.1	
-2°	3833.1	1064.8	6.4		82.7	90	2180	80.1	
	4483.1	1245.3	4.4		63.7			83.8	
	4892.3	1359.0	3.0		50.2			80.1	
0°	4106.7	1140.7	6.5		90.1	110	2350	80.1	
	4850.6	1347.4	4.4	68.7	84.1				
	5243.9	1456.6	3.0	53.8	80.1				
+2°	4484.0	1245.5	6.6	100.0	110	2350	80.1		
	5144.6	1429.1	4.6	75.8			84.6		
	5553.3	1542.6	3.3	62.9			80.1		
+4°	4901.2	1361.5	6.3	104.1	132	2580	80.1		
	5512.1	1531.1	4.6	81.5			84.3		
	5847.7	1624.4	3.6	72.4			80.1		

700QZ-130

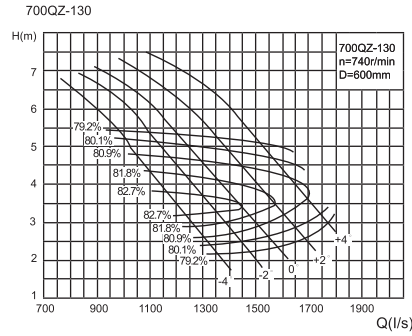

叶片安装角度 Blade angle	流量 Flow Q		扬程 Head H (m)	转速 Speed n (r/min)	功率 Power P (kW)		重量 weight (kg)	效率 Efficiency η (%)	叶轮直径 Impeller diameter (mm)
	(m³/h)	l/s			轴功率 Shaft power	电机功率 Motor power			
-4°	3528.5	980.1	5.4	740	65.7	75	2010	79.2	600
	4558.4	1266.3	3.0		44.6	79.2			
	4885.7	1357.2	2.2		36.7	79.2			
-2°	3935.9	1093.3	5.4	740	73.2	90	2150	79.2	600
	4900.8	1361.3	3.2		51.4			83.7	
	5307.4	1474.3	2.3		41.8			79.2	
0°	4346.1	1207.3	5.3	740	79.3	90	2150	79.2	600
	5225.8	1451.6	3.3		56.9			83.3	
	5675.2	1576.4	2.3		44.7			79.2	
+2°	4946.2	1373.9	5.0	740	44.0	110	2300	79.2	600
	5629.9	1563.9	3.5		65.8			82.5	
	6061.4	1683.7	2.6		54.2			79.2	
+4°	5447.0	1513.1	5.0	740	93.6	110	2300	79.2	600
	6026.7	1674.1	3.6		73.2			81.7	
	6382.6	1772.9	2.9		64.0			79.2	

800QZ-70G

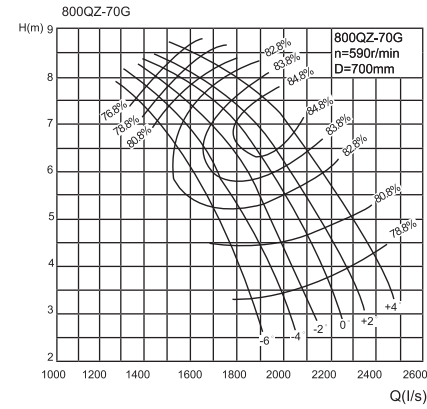

叶片安装角度 Blade angle	流量 Flow Q		扬程 Head H (m)	转速 Speed n (r/min)	功率 Power P (kW)		重量 weight (kg)	效率 Efficiency η (%)	叶轮直径 Impeller diameter (mm)
	(m³/h)	l/s			轴功率 Shaft power	电机功率 Motor power			
-6°	6380.0	1772.2	4.4	590	94.5	160	3480	80.8	700
	5170.0	1436.1	6.2		104.9			83.1	
	5100.0	1416.7	7.3		128.5			78.8	
-4°	6810.0	1891.7	4.4	590	100.9	160	3480	80.8	700
	6000.0	1666.7	6.3		122.4			84.0	
	5065.0	1406.9	7.8		139.9			76.8	
-2°	7170.0	1991.7	4.4	590	106.2	185	3650	80.8	700
	6365.0	1768.1	6.4		131.5			84.2	
	5390.0	1497.2	7.8		145.1			78.8	
0°	7535.0	2093.1	4.6	590	116.7	185	3650	80.8	700
	6620.0	1838.9	6.7		140.6			85.8	
	5540.0	1538.9	8.0		153.0			78.8	
+2°	7790.0	2163.9	4.7	590	123.3	200	3750	80.8	700
	6830.0	1897.2	6.8		147.9			85.4	
	5645.0	1568.1	8.1		157.8			78.8	
+4°	8210.0	2280.6	5.0	590	138.2	220	3900	80.8	700
	7770.0	2158.3	6.0		153.1			82.8	
	7130.0	1980.6	7.2		164.7			84.8	

700QZ-160

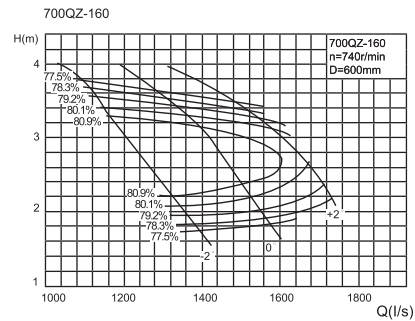

叶片安装角度 Blade angle	流量 Flow Q		扬程 Head H (m)	转速 Speed n (r/min)	功率 Power P (kW)		重量 weight (kg)	效率 Efficiency η (%)	叶轮直径 Impeller diameter (mm)
	(m³/h)	l/s			轴功率 Shaft power	电机功率 Motor power			
-2°	3990.2	1108.4	3.6	740	19.9	55	1860	78.1	600
	4556.4	1265.7	2.6		39.2			82.0	
	4977.3	1382.8	1.8		31.1			78.1	
0°	4713.3	1309.3	3.5	740	57.3	75	1980	78.1	600
	5291.3	1469.8	2.6		46.0			81.2	
	5625.3	1562.6	1.9		37.1			78.1	
+2°	5474.0	1520.6	3.3	740	62.8	75	1980	78.1	600
	5908.6	1641.3	2.8		56.2			79.9	
	6233.5	1731.5	2.2		47.6			78.1	

800QZ-70D

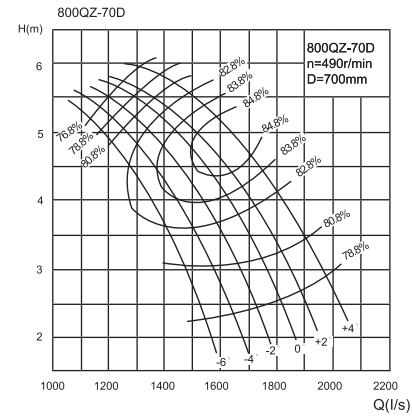

叶片安装角度 Blade angle	流量 Flow Q		扬程 Head H (m)	转速 Speed n (r/min)	功率 Power P (kW)		重量 weight (kg)	效率 Efficiency η (%)	叶轮直径 Impeller diameter (mm)
	(m³/h)	l/s			轴功率 Shaft power	电机功率 Motor power			
-6°	5295.4	1470.9	3.0	490	54.5	90	2780	80.3	700
	4291.1	1192.0	4.3		60.5			82.6	
	4233.0	1175.8	5.0		74.1			78.3	
-4°	5652.3	1570.1	3.0	490	58.1	110	3120	80.3	700
	4980.0	1383.3	4.3		70.5			83.5	
	4204.0	1167.8	5.4		80.7			76.3	
-2°	5951.1	1653.1	3.0	490	61.2	110	3120	80.3	700
	5283.0	1467.5	4.4		75.8			83.7	
	4473.7	1242.7	5.4		83.6			78.3	
0°	6254.1	1737.2	3.2	490	67.2	110	3120	80.3	700
	5494.6	1526.3	4.6		81.0			85.3	
	4598.2	1277.3	5.5		88.2			78.3	
+2°	6465.7	1796.0	3.2	490	71.0	132	3500	80.3	700
	5668.9	1574.7	4.7		85.2			84.9	
	4685.4	1301.5	5.6		91.0			78.3	
+4°	6714.3	1892.9	3.5	490	79.6	132	3500	80.3	700
	6449.1	1791.4	4.1		88.2			82.3	
	5917.9	1643.9	5.0		96.1			83.9	

800QZ-100

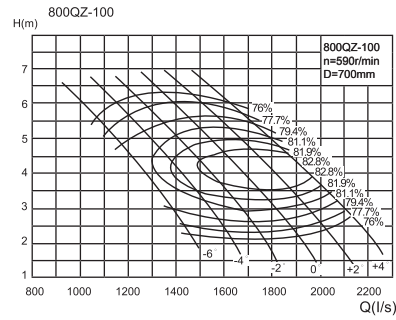

叶片安装角度 Blade angle	流量 Flow Q		扬程 Head H	转速 Speed n	功率 Power P (kW)		重量 weight (kg)	效率 Efficiency η (%)	叶轮直径 Impeller diameter (mm)
	(m³/h)	l/s	(m)	(r/min)	轴功率 Shaft power	电机功率 Motor power			
-6°	4270.6	1186.3	4.7	590	68.5	75	2580	79.4	700
	4652.1	1292.3	3.6		56.0	75		81.4	
	5012.9	1392.5	2.9		49.5	75		79.4	
-4°	4533.7	1259.4	5.2	590	81.2	90	2650	79.4	700
	5210.4	1447.3	3.7		63.5	90		82.5	
	5690.0	1580.6	2.6		50.9	90		79.4	
-2°	4852.7	1348.0	5.5	590	91.4	110	2790	79.4	700
	5675.6	1576.5	3.8		70.3	110		83.1	
	6193.5	1720.4	2.6		55.4	110		79.4	
0°	5199.0	1444.2	5.6	590	99.5	132	2950	79.4	700
	6140.8	1705.8	3.8		75.8	132		83.4	
	6638.7	1844.1	2.6		59.4	132		79.4	
+2°	5676.6	1576.8	5.7	590	110.4	150	3100	79.4	700
	6512.9	1809.2	4.0		83.7	150		83.9	
	7030.4	1952.9	2.9		69.4	150		79.4	
+4°	6204.9	1723.6	5.4	590	114.9	170	3250	79.4	700
	6978.2	1938.4	4.0		90.0	170		83.6	
	7403.0	2056.4	3.2		80.0	170		79.4	

800QZ-130

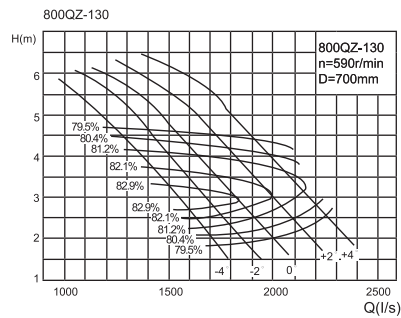

叶片安装角度 Blade angle	流量 Flow Q		扬程 Head H	转速 Speed n	功率 Power P (kW)		重量 weight (kg)	效率 Efficiency η (%)	叶轮直径 Impeller diameter (mm)
	(m³/h)	l/s	(m)	(r/min)	轴功率 Shaft power	电机功率 Motor power			
-4°	4468.1	1241.1	4.7	590	71.6	90	2600	79.5	700
	5772.2	1603.4	2.6		48.7	90		84.3	
	6186.8	1718.5	1.9		40.1	90		79.5	
-2°	4983.9	1384.4	4.7	590	79.9	110	2730	79.5	700
	6205.9	1723.9	2.8		56.1	110		84.0	
	6720.7	1866.9	2.0		45.6	110		79.5	
0°	5503.4	1528.7	4.6	590	86.5	132	2900	79.5	700
	6617.4	1838.2	2.9		62.1	132		83.6	
	7186.5	1996.2	2.0		48.7	132		79.5	
+2°	6363.3	1739.8	4.3	590	92.7	150	3100	79.5	700
	7129.1	1980.3	3.1		71.7	150		82.8	
	7675.4	2132.1	2.3		59.2	150		79.5	
+4°	6897.5	1916.0	4.3	590	102.1	170	3250	79.5	700
	7631.5	2119.9	3.2		79.8	170		82.0	
	8082.2	2245.1	2.5		69.8	170		79.5	

800QZ-160

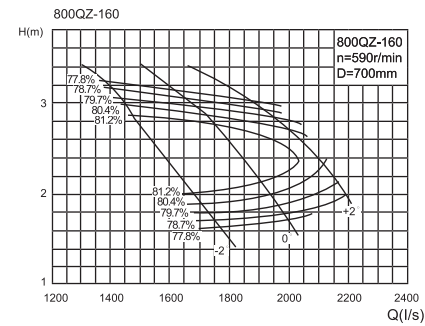

叶片安装角度 Blade angle	流量 Flow Q		扬程 Head H	转速 Speed n	功率 Power P (kW)		重量 weight (kg)	效率 Efficiency η (%)	叶轮直径 Impeller diameter (mm)
	(m³/h)	l/s	(m)	(r/min)	轴功率 Shaft power	电机功率 Motor power			
-2°	5051.6	1403.2	3.1	590	54.4	75	2490	78.7	700
	5768.4	1602.3	2.2		42.7	75		82.6	
	6301.3	1750.4	1.6		33.9	75		78.7	
0°	5967.0	1657.5	3.0	590	62.4	90	2650	78.7	700
	6698.8	1860.8	2.2		50.1	90		81.8	
	7121.6	1978.2	1.6		40.5	90		78.7	
+2°	6930.1	1925.0	2.9	590	68.4	110	2790	78.7	700
	7480.3	2077.9	2.4		61.2	110		80.5	
	7891.6	2192.1	1.9		51.9	110		78.7	

900QZ-70G

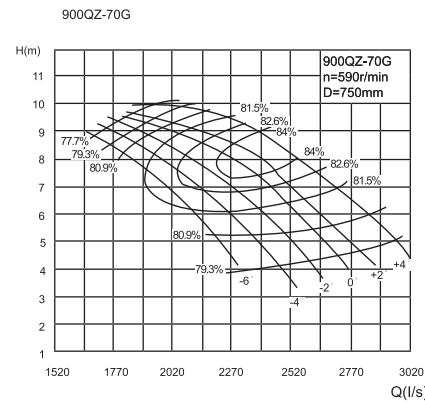

叶片安装角度 Blade angle	流量 Flow Q		扬程 Head H	转速 Speed n	功率 Power P (kW)		重量 weight (kg)	效率 Efficiency η (%)	叶轮直径 Impeller diameter (mm)
	(m³/h)	l/s	(m)	(r/min)	轴功率 Shaft power	电机功率 Motor power			
-6°	8266.7	2296.3	4.0	590	112.1	150	4860	79.3	750
	7720.0	2144.5	5.8		147.8	150		81.9	
	6864.9	1906.9	7.7		174.1	150		82.4	
-4°	6315.8	1754.4	8.5	590	183.6	200	5100	79.3	750
	8821.6	2450.4	4.1		123.1	200		79.3	
	8192.3	2275.6	5.8		156.8	200		81.9	
-2°	7311.5	2031.0	7.6	590	181.0	250	5620	83.2	750
	6498.6	1805.2	8.8		196.5	250		79.3	
	9274.0	2576.1	4.2		133.0	250		79.3	
0°	8672.7	2409.1	5.8	590	166.2	300	6130	81.9	750
	7466.2	2073.9	8.1		198.6	300		83.2	
	6682.2	1856.2	9.2		209.8	300		79.3	
+2°	9719.7	2699.9	4.4	590	146.9	350	6650	79.3	750
	9199.5	2555.4	5.8		177.5	350		81.4	
	8336.2	2315.6	7.7		207.7	350		83.8	
+4°	6870.7	1908.5	9.4	590	221.1	400	7150	79.6	750
	10051.4	2792.0	4.6		159.7	400		79.3	
	8693.4	2414.8	7.6		213.4	400		82.9	
+4°	8048.4	2235.7	8.5	590	221.1	450	7670	83.9	750
	7013.8	1948.3	9.5		228.4	450		79.3	
	10577.3	2938.1	5.0		171.7	450		79.3	
+4°	9318.6	2588.5	7.9	590	228.7	500	8190	83.3	750
	8495.8	2359.9	8.9		245.3	500		83.9	
	7397.6	2054.9	9.8		249.4	500		79.3	

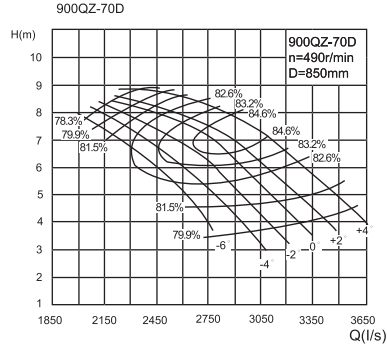

900QZ-70D										
叶片安装角度 Blade angle	流量 Flow Q		扬程 Head H	转速 Speed n	功率 Power P (kW)		重量 weight	效率 Efficiency η	叶轮直径 Impeller diameter	
	(m³/h)	l/s	(m)	(r/min)	轴功率 Shaft power	电机功率 Motor power	(kg)	(%)	(mm)	(mm)
-6°	9996	2776.7	3.5	490	119.0	220	6100	80.0	850	
	9335	2593.1	5.1		156.8			82.6		
	8301	2305.8	6.8		184.8			83.1		
	7637	2121.4	7.5		194.7			80.0		
-4°	10667	2963.1	3.6	130.6	80.0					
	9906	2751.7	5.1	166.4	82.6					
	8841	2455.8	6.7	192.0	83.9					
	7858	2183.8	7.8	208.4	80.0					
-2°	11214	3115.0	3.7	141.1	80.0					
	10487	2913.1	5.1	176.3	82.5					
	8028	2507.8	7.2	210.7	83.9					
	8080	2244.4	8.1	222.5	80.0					
0°	11753	3264.7	3.9	155.8	80.0					
	11124	3090.0	5.1	188.0	82.1					
	10080	2800.0	6.8	220.4	84.6					
	8308	2307.8	8.3	234.5	80.0					
+2°	12154	3376.1	4.1	169.4	80.0					
	10521	2920.0	6.7	226.4	84.6					
	9732	2703.3	7.5	234.7	84.6					
	8481	2355.8	8.4	242.2	80.0					
+4°	12790	3552.8	4.4	182.2	80.0					
	11268	3130.0	6.7	242.7	84.0					
	10273	2853.6	7.9	261.1	84.6					
	8945	2484.7	8.7	264.6	80.0					

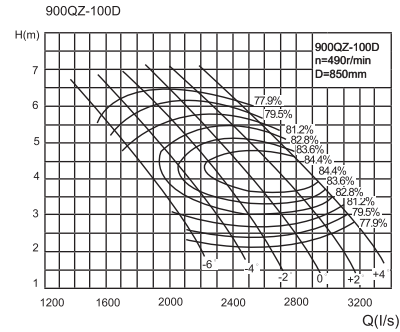

900QZ-100D										
叶片安装角度 Blade angle	流量 Flow Q		扬程 Head H	转速 Speed n	功率 Power P (kW)		重量 weight	效率 Efficiency η	叶轮直径 Impeller diameter	
	(m³/h)	l/s	(m)	(r/min)	轴功率 Shaft power	电机功率 Motor power	(kg)	(%)	(mm)	(mm)
-6°	6350	1763.9	4.8	490	102.6	132	4540	80.2	850	
	6917	1921.5	3.7		83.9			82.2		
	7454	2070.5	2.9		74.1			80.2		
-4°	6741	1872.6	5.3	121.5	80.2					
	7747	2152.1	3.8	95.0	83.3					
	8461	2350.2	2.7	76.2	80.2					
-2°	7216	2004.3	5.6	136.7	80.2					
	8439	2344.2	3.8	105.3	83.9					
	9209	2558.2	2.7	83.0	80.2					
0°	7731	2147.4	5.7	148.9	80.2					
	9131	2536.4	3.8	113.5	84.2					
	9871	2742.0	2.7	88.9	80.2					
+2°	8441	2344.7	5.8	165.2	80.2					
	9684	2690.1	4.0	125.3	84.7					
	10454	2903.8	2.9	103.9	80.2					
+4°	9226	2562.9	5.5	172.0	80.2					
	10376	2882.3	4.0	134.8	84.4					
	11008	3057.7	3.2	119.7	80.2					

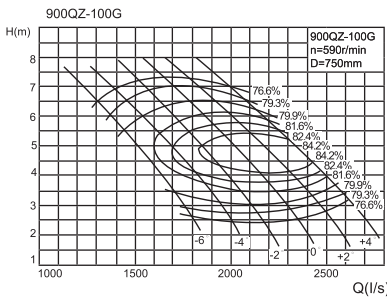

900QZ-100G										
叶片安装角度 Blade angle	流量 Flow Q		扬程 Head H	转速 Speed n	功率 Power P (kW)		重量 weight	效率 Efficiency η	叶轮直径 Impeller diameter	
	(m³/h)	l/s	(m)	(r/min)	轴功率 Shaft power	电机功率 Motor power	(kg)	(%)	(mm)	(mm)
-6°	5253.0	1459.2	5.4	590	96.2	110	3400	79.9	750	
	5722.2	1589.5	4.1		78.7			81.9		
	6166.0	1712.8	3.3		69.5			79.9		
	5576.6	1548.1	6.0		114.0			79.9		
-4°	6408.9	1780.2	4.2	89.1	83.0					
	6998.9	1944.1	3.0	71.5	79.9					
	5968.9	1658.0	6.3	128.3	79.9					
	6981.1	1939.2	4.3	98.7	83.6					
-2°	7618.2	2116.2	3.0	77.8	79.9					
	6394.9	1776.4	6.4	139.7	79.9					
	7553.3	2098.1	4.3	106.4	83.9					
	8165.7	2268.3	3.0	83.4	79.9					
0°	6982.4	1939.5	6.5	155.0	79.9					
	8011.1	2225.3	4.6	117.6	84.4					
	8674.5	2402.1	3.3	97.5	79.9					
	7632.1	2120.0	6.2	161.3	79.9					
+4°	8283.3	2384.3	4.6	126.4	84.1					
	9105.9	2529.4	3.6	112.3	79.9					

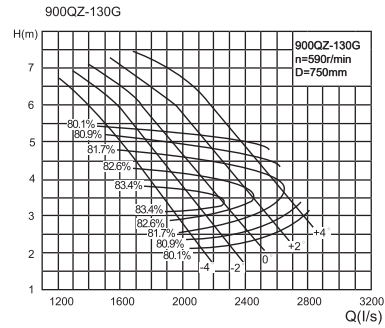

900QZ-130G										
叶片安装角度 Blade angle	流量 Flow Q		扬程 Head H	转速 Speed n	功率 Power P (kW)		重量 weight	效率 Efficiency η	叶轮直径 Impeller diameter	
	(m³/h)	l/s	(m)	(r/min)	轴功率 Shaft power	电机功率 Motor power	(kg)	(%)	(mm)	(mm)
-4°	5495.0	1526.4	5.4	590	100.3	132	3300	80.1	750	
	7098.9	1971.9	3.0		68.2			84.9		
	7608.7	2113.5	2.2		56.1			80.1		
-2°	6129.4	1702.6	5.4	111.9	80.1					
	7632.2	2120.1	3.2	78.7	84.6					
	8265.4	2295.9	2.3	63.8	80.1					
0°	6768.3	1880.1	5.3	121.2	80.1					
	8138.2	2260.6	3.3	87.0	84.2					
	8838.1	2455.0	2.3	68.3	80.1					
+2°	7702.8	2139.7	5.0	129.8	80.1					
	8767.6	2435.4	3.5	100.5	83.4					
	9439.5	2622.1	2.6	82.9	80.1					
+4°	8482.8	2356.3	5.0	143.0	80.1					
	9385.5	2607.1	3.6	111.8	82.6					
	9939.8	2761.1	2.9	97.7	80.1					

900QZ-130D

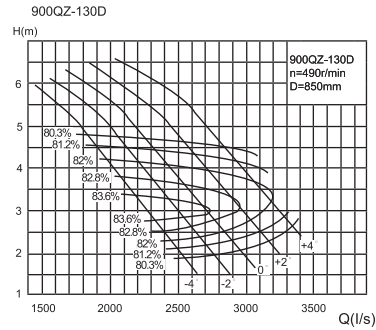

叶片安装角度 Blade angle	流量 Flow Q		扬程 Head H (m)	转速 Speed n (r/min)	功率 Power P (kW)		重量 weight (kg)	效率 Efficiency η (%)	叶轮直径 impeller diameter (mm)
	(m³/h)	l/s			轴功率 Shaft power	电机功率 Motor power			
-4°	6644	1845.5	4.8	490	107.2	132	4300	80.3	850
	8583	2384.2	2.7		72.9			85.1	
	9199	2555.4	1.9		59.9			80.3	
-2°	7411	2058.8	4.8	119.6	84.8				
	9228	2563.3	2.8	84.0	84.85				
	9993	2775.9	2.0	68.2	80.3				
0°	8183	2273.1	4.7	129.5	80.3				
	9840	2733.2	2.9	93.0	84.4				
	10688	2968.3	2.0	72.9	80.3				
+2°	9313	2587.0	4.4	138.7	80.3				
	10601	2944.6	3.1	107.4	83.6				
	11413	3170.3	2.3	88.5	80.3				
+4°	10256	2848.9	4.4	152.7	80.3				
	11348	3152.1	3.2	119.5	82.8				
	12018	3338.3	2.6	104.4	80.3				

900QZ-160D

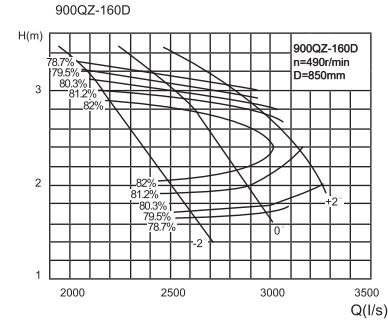

叶片安装角度 Blade angle	流量 Flow Q		扬程 Head H (m)	转速 Speed n (r/min)	功率 Power P (kW)		重量 weight (kg)	效率 Efficiency η (%)	叶轮直径 impeller diameter (mm)
	(m³/h)	l/s			轴功率 Shaft power	电机功率 Motor power			
-2°	7509.6	2086.0	3.2	490	81.4	90	3500	79.5	850
	8575.1	2382.0	2.3		64.0			83.4	
	9367.3	2602.0	1.6		50.8			79.5	
0°	8870.4	2464.0	3.1	93.5	79.5				
	9958.2	2766.2	2.3	75.0	110	3800	82.6		
	10586.6	2940.8	1.7	60.6	79.5				
+2°	10302.1	2861.7	2.9	102.4	79.5				
	11120.0	3088.9	2.5	91.7	132	4100	81.3		
	11731.4	3258.7	1.9	77.7	79.5				

1000QZ-70

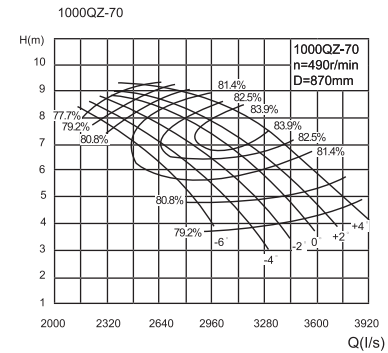

叶片安装角度 Blade angle	流量 Flow Q		扬程 Head H (m)	转速 Speed n (r/min)	功率 Power P (kW)		重量 weight (kg)	效率 Efficiency η (%)	叶轮直径 impeller diameter (mm)
	(m³/h)	l/s			轴功率 Shaft power	电机功率 Motor power			
-6°	10715.7	2976.6	3.7	490	133.1	250	6500	80.3	870
	10007.1	2779.8	5.3		175.4			82.9	
	8898.7	2471.9	7.1		206.7			83.4	
	8186.9	2274.1	7.9		217.9			80.3	
-4°	11435.0	3176.4	3.8	146.1	80.3				
	10619.2	2949.8	5.3	186.2	82.9				
	9477.6	2632.7	7.0	214.9	84.2				
	8423.8	2339.9	8.2	233.2	80.3				
-2°	12021.4	3339.3	3.9	157.8	80.3				
	11242.1	3122.8	5.3	197.3	82.8				
	9678.0	2688.3	7.5	235.8	84.2				
	8661.8	2406.0	8.5	249.0	80.3				
0°	12599.2	3499.8	4.1	174.4	280	6800	80.3		
	11924.9	3312.5	5.3	210.3	82.4				
	10805.8	3001.6	7.1	246.6	84.9				
	8906.2	2473.9	8.7	262.3	80.3				
+2°	13029.1	3619.2	4.3	189.6	80.3				
	11268.9	3130.2	7.0	253.4	84.5				
	10432.7	2898.0	7.9	262.6	84.9				
	9091.6	2525.5	8.8	271.0	80.3				
+4°	13710.9	3808.6	4.6	203.9	315	7200	80.3		
	12079.3	3355.4	7.0	271.6	84.3				
	11012.7	3059.1	8.3	293.1	84.9				
	9588.9	2663.6	9.1	296.0	80.3				

900QZ-160G

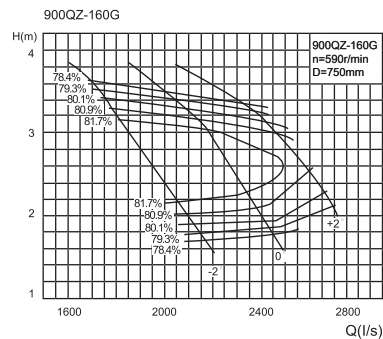

叶片安装角度 Blade angle	流量 Flow Q		扬程 Head H (m)	转速 Speed n (r/min)	功率 Power P (kW)		重量 weight (kg)	效率 Efficiency η (%)	叶轮直径 impeller diameter (mm)
	(m³/h)	l/s			轴功率 Shaft power	电机功率 Motor power			
-2°	6212.7	1725.8	3.6	590	76.2	90	2850	79.3	750
	7094.3	1970.6	2.6		59.9			83.2	
	7749.7	2152.7	1.8		47.5			79.3	
0°	7338.6	2038.5	3.5	87.5	79.3				
	8238.6	2288.5	2.6	70.2	82.4				
	8758.6	2432.9	1.9	56.7	79.3				
+2°	8523.0	2367.5	3.3	95.8	79.3				
	9199.7	2555.5	2.9	85.8	81.1				
	9705.6	2696.0	2.2	72.7	79.3				

1000QZ-100

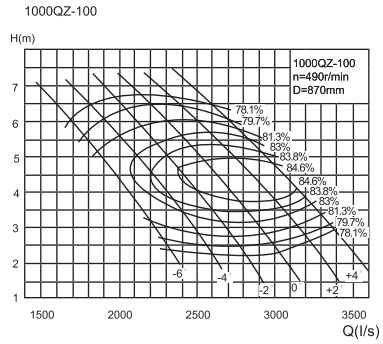

叶片安装角度 Blade angle	流量 Flow Q		扬程Head H	转速Speed n	功率Power P (kW)		重量 weight (kg)	效率 Efficiency η (%)	叶轮直径 Impeller diameter (mm)
	(m³/h)	l/s	(m)	(r/min)	轴功率 Shaft power	电机功率 Motor power			
-6°	6809.5	1891.5	5.0	490	114.9	132	4800	80.5	870
	7417.8	2060.5	3.8		83.0	80.5			
	7993.1	2220.3	3.1		83.0	80.5			
-4°	7229.1	2008.1	5.6	490	136.0	160	5100	80.5	870
	8307.9	2307.8	3.9		106.4			83.6	
	9072.8	2520.2	2.8		85.3			80.5	
-2°	7737.6	2149.3	5.9	490	153.1	185	5500	80.5	870
	9049.7	2513.8	4.0		117.9			84.2	
	9875.6	2743.2	2.8		92.9			80.5	
0°	8289.8	2302.7	6.0	490	166.7	200	5800	80.4	870
	9791.5	2719.9	4.0		127.1			84.5	
	10585.4	2940.4	2.8		99.6			80.5	
+2°	9051.4	2514.3	6.0	490	185.0	220	6100	80.5	870
	10384.9	2884.7	4.2		140.4			85.0	
	11209.9	3113.9	3.1		116.4			80.5	
+4°	9893.7	2748.2	5.8	490	192.6	220	6100	80.5	870
	11126.7	3090.8	4.2		150.9			84.7	
	11804.2	3278.9	3.4		134.0			80.5	

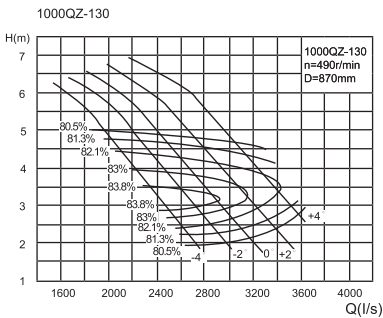

1000QZ-130

叶片安装角度 Blade angle	流量 Flow Q		扬程Head H	转速Speed n	功率Power P (kW)		重量 weight (kg)	效率 Efficiency η (%)	叶轮直径 Impeller diameter (mm)
	(m³/h)	l/s	(m)	(r/min)	轴功率 Shaft power	电机功率 Motor power			
-4°	7124.4	1979.0	5.0	490	120.2	132	4700	80.5	870
	9203.8	2556.6	2.8		81.7			85.3	
	9846.8	2740.2	2.0		67.2			80.5	
-2°	7945.9	2207.5	5.0	490	134.0	160	5000	80.5	870
	9895.3	2748.7	3.0		94.2			85.0	
	10716.2	2976.7	2.1		76.5			80.5	
0°	8775.3	2437.6	4.9	490	145.2	185	5300	80.5	870
	10551.4	2930.9	3.1		104.2			84.6	
	11458.9	3183.0	2.1		81.8			80.5	
+2°	9986.8	2774.1	4.6	490	155.5	200	5600	80.5	870
	11367.4	3157.6	3.3		120.4			83.8	
	12238.5	3399.6	2.4		99.2			80.5	
+4°	10998.1	3055.0	4.6	490	171.2	220	6000	80.5	870
	12168.5	3380.1	3.4		134.0			83.0	
	12887.2	3579.8	2.7		117.0			80.5	

1000QZ-160

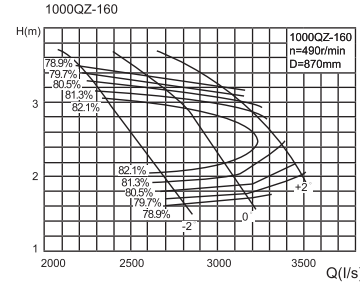

叶片安装角度 Blade angle	流量 Flow Q		扬程Head H	转速Speed n	功率Power P (kW)		重量 weight (kg)	效率 Efficiency η (%)	叶轮直径 Impeller diameter (mm)
	(m³/h)	l/s	(m)	(r/min)	轴功率 Shaft power	电机功率 Motor power			
-2°	8052.2	2236.7	3.5	490	96.3	110	4400	79.7	870
	9194.8	2554.1	2.5		75.7			83.6	
	10044.2	2790.1	1.8		60.1			79.7	
0°	9511.4	2642.1	3.4	490	110.6	132	4700	79.7	870
	10677.8	2966.1	2.5		88.8			82.8	
	11351.9	3153.3	1.8		71.7			79.7	
+2°	11046.5	3068.5	3.2	490	121.1	160	5100	79.7	870
	11923.6	3312.1	2.7		108.5			81.5	
	12579.2	3494.2	2.1		91.9			79.7	

1200QZ-70

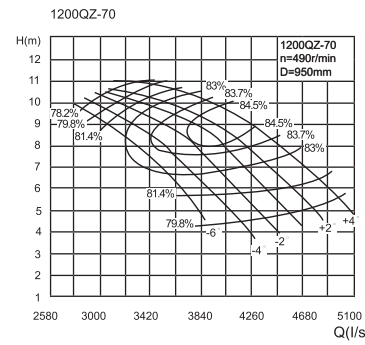

叶片安装角度 Blade angle	流量 Flow Q		扬程Head H	转速Speed n	功率Power P (kW)		重量 weight (kg)	效率 Efficiency η (%)	叶轮直径 Impeller diameter (mm)
	(m³/h)	l/s	(m)	(r/min)	轴功率 Shaft power	电机功率 Motor power			
-6°	13954.4	3876.2	4.4	490	205.1	220	6100	80.9	950
	13031.7	3619.9	6.4		270.4			83.5	
	11588.2	3218.9	8.5		318.7			84.0	
-4°	10661.3	2961.5	9.4	490	335.8	400	9400	80.9	950
	14891.1	4136.4	4.5		225.1			80.9	
	13282.8	3841.3	6.4		286.9			83.5	
-2°	12342.0	3428.3	8.4	490	331.3	450	9800	84.8	950
	10969.8	3047.2	9.7		359.3			80.9	
	15654.7	4348.5	4.6		243.2			80.9	
0°	14639.9	4066.6	6.4	490	304.1	500	10300	83.4	950
	12603.1	3500.9	9.0		363.5			84.8	
	11279.7	3133.2	10.1		383.7			80.9	
+2°	16407.2	4557.6	4.9	490	268.7	550	10700	80.9	950
	15529.1	4313.6	6.4		324.2			83.0	
	14071.7	3908.8	8.5		380.2			85.5	
+4°	11598.0	3221.7	10.4	490	404.2	600	11200	80.9	950
	16967.0	4713.1	5.1		292.1			80.9	
	14674.8	4076.3	8.4		390.7			85.1	
+4°	13585.9	3773.9	9.4	490	404.9	650	11700	85.5	950
	11839.5	3288.7	10.5		417.6			80.9	
	17854.8	4959.7	5.5		314.4			80.9	
+4°	15730.1	4369.5	8.4	490	418.8	700	12200	84.9	950
	14341.1	3983.6	9.9		452.0			85.5	
	12487.2	3468.7	10.9		456.2			80.9	

1200QZ-100

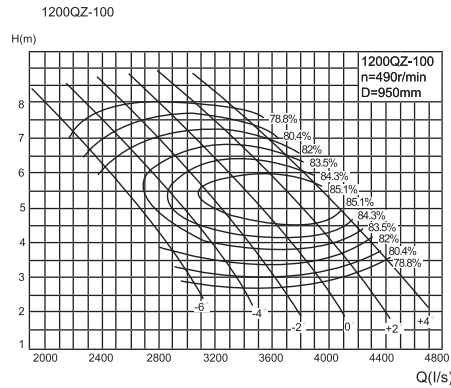

叶片安装角度 Blade angle	流量 Flow Q		扬程 Head H (m)	转速 Speed n (r/min)	功率 Power P (kW)		重量 weight (kg)	效率 Efficiency η (%)	叶轮直径 impeller diameter (mm)
	(m³/h)	l/s			轴功率 Shaft power	电机功率 Motor power			
-6°	8865.1	2462.5	6.0	490	178.3	200	7800	80.5	950
	9657.0	2682.5	4.6		82.5				
	10406.0	2890.5	3.7		80.5				
-4°	9411.3	2614.2	6.6		211.2	250	8200	80.5	
	10815.8	3004.4	4.7		165.2			83.6	
	11811.6	3281.0	3.3		132.5			80.5	
-2°	10073.3	2798.1	7.0		237.7	280	8500	80.5	
	11781.5	3272.7	4.8		183.0			84.2	
	12856.7	3571.3	3.3		144.2			80.5	
0°	10792.2	2997.8	7.1		258.9	280	8500	80.5	
	12747.2	3540.9	4.8		197.3			84.5	
	13780.3	3828.0	3.3		154.6			80.5	
+2°	11783.7	3273.2	7.2	287.2	315	8700	80.5		
	13519.8	3755.5	5.0	218.0			85.0		
	14593.9	4053.9	3.7	180.7			80.5		
+4°	12880.3	3577.9	6.9	299.0	355	9000	80.5		
	14485.5	4023.8	5.0	234.4			84.7		
	15367.5	4268.8	4.0	208.1			80.5		

1200QZ-130

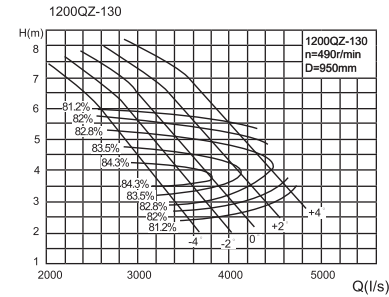

叶片安装角度 Blade angle	流量 Flow Q		扬程 Head H (m)	转速 Speed n (r/min)	功率 Power P (kW)		重量 weight (kg)	效率 Efficiency η (%)	叶轮直径 impeller diameter (mm)
	(m³/h)	l/s			轴功率 Shaft power	电机功率 Motor power			
-4°	9275.0	2576.4	6.0	490	185.4	200	7700	81.0	
	11982.2	3328.4	3.3		126.1			85.8	
	12842.7	3567.4	2.4		103.7			81.0	
-2°	10345.9	2873.9	6.0		206.9	220	7900	81.0	
	12882.4	3578.5	3.5		145.5			85.5	
	13951.1	3875.3	2.5		118.0			81.0	
0°	11424.2	3173.4	5.8		224.0	250	8100	81.0	
	13736.5	3815.7	3.7		160.9			85.1	
	14917.9	4143.9	2.5		126.2			81.0	
+2°	13001.2	3611.5	5.5		240.0	280	8400	81.0	
	14798.8	4110.8	3.9		185.9			84.3	
	15933.0	4425.8	2.9		153.2			81.0	
+4°	14318.1	3977.3	5.5	264.3	315	8800	81.0		
	15841.8	4400.5	4.0	206.8			83.5		
	16777.4	4660.4	3.2	180.6			81.0		

1200QZ-160

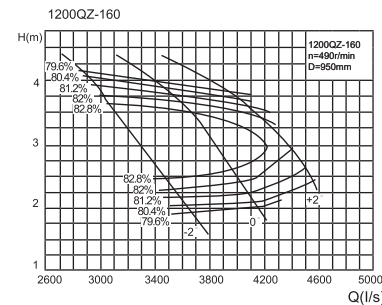

叶片安装角度 Blade angle	流量 Flow Q		扬程 Head H (m)	转速 Speed n (r/min)	功率 Power P (kW)		重量 weight (kg)	效率 Efficiency η (%)	叶轮直径 impeller diameter (mm)
	(m³/h)	l/s			轴功率 Shaft power	电机功率 Motor power			
-2°	10486.2	2912.8	4.0	490	140.4	160	7200	80.4	
	11974.2	3326.2	2.9		110.4			84.3	
	13080.3	3633.4	2.0		87.5			80.4	
0°	12386.6	3440.7	3.8		161.2	185	7500	80.4	
	13905.5	3862.6	2.9		129.4			83.5	
	14783.3	4106.5	2.1		104.4			80.4	
+2°	14385.7	3996.0	3.6		176.5	200	7700	80.4	
	15527.8	4313.3	3.1		158.1			82.2	
	16381.6	4550.5	2.4		134.0			80.4	

1400QZ-70

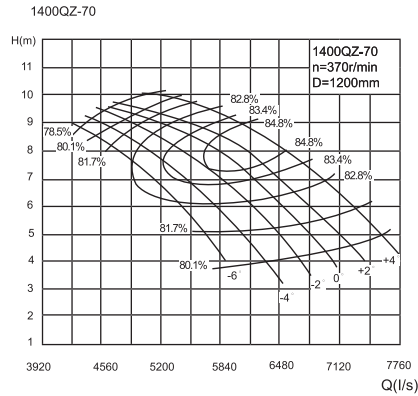

1400QZ-100

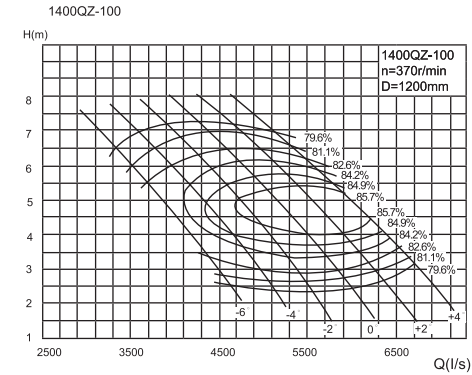

叶片安装角度 Blade angle	流量 Flow Q		扬程 Head H (m)	转速 Speed n (r/min)	功率 Power P (kW)		重量 weight (kg)	效率 Efficiency η (%)	叶轮直径 Impeller diameter (mm)
	(m³/h)	l/s			轴功率 Shaft power	电机功率 Motor power			
-6°	21241.5	5900.4	4.0	370	282.9	500	11800	81.2	1200
	19836.9	5510.2	5.8		373.0			83.8	
	17639.6	4899.9	7.7		439.7			84.3	
	16228.6	4508.0	8.5		463.2			81.2	
-4°	22667.4	6296.5	4.1		310.5	560	12400	81.2	
	21050.3	5847.3	5.8		395.9			83.8	
	18787.1	5218.6	7.6		457.0			85.1	
	16698.3	4638.4	8.9		495.6			81.2	
-2°	23829.8	6619.4	4.2		335.5	630	13100	81.2	
	22284.9	6190.2	5.8		419.6			83.7	
	19184.5	5329.0	8.2		501.5			85.1	
	17170.0	4769.4	9.2		529.2			81.2	
0°	24975.1	6637.5	4.4		370.6	710	13900	81.2	
	23638.5	6566.3	5.8		447.2			83.3	
	21420.0	5950.0	7.7		524.6			85.8	
	17654.5	4904.4	9.4		557.6			81.2	
+2°	25827.3	7174.2	4.7	403.0	710	13900	81.2		
	22338.0	6205.0	7.6	539.0			85.5		
	20680.5	5744.6	8.5	558.6			85.8		
	18022.1	5006.1	9.5	576.1			81.2		
+4°	27178.8	7549.7	5.0	433.7	710	13900	81.2		
	23944.5	6651.3	7.6	577.8			85.2		
	21830.1	6063.9	9.0	623.4			85.8		
	19008.1	5280.0	9.9	629.3			81.2		

叶片安装角度 Blade angle	流量 Flow Q		扬程 Head H (m)	转速 Speed n (r/min)	功率 Power P (kW)		重量 weight (kg)	效率 Efficiency η (%)	叶轮直径 Impeller diameter (mm)
	(m³/h)	l/s			轴功率 Shaft power	电机功率 Motor power			
-6°	13492.7	3748.0	5.4	370	244.0	280	9700	81.5	1200
	14697.9	4082.8	4.2		199.6			83.5	
	15837.8	4399.4	3.3		176.2			81.5	
	14323.9	3978.9	6.0		288.9			81.5	
-4°	16461.6	4572.7	4.3		226.1	315	10100	84.6	
	17977.2	4993.7	3.0		181.3			81.5	
	15331.5	4258.8	6.4		325.2			81.5	
	17931.4	4981.0	4.4		250.5			85.2	
-2°	19567.8	5435.5	3.0		197.3	355	10400	81.5	
	16425.7	4562.7	6.5		354.2			81.5	
	19401.2	5389.2	4.4		270.1			85.5	
	20974.2	5826.2	3.0		211.5			81.5	
0°	17934.7	4981.9	6.6		392.5	400	10800	81.5	
	20577.1	5715.9	4.6		298.4			86	
	22211.8	6169.9	3.3		247.2			81.5	
	19603.7	5445.5	6.3		409.0			81.5	
+2°	22046.9	6124.1	4.6	320.8	450	11200	85.7		
	23389.3	6497.0	3.6	274.7			81.5		

1400QZ-130

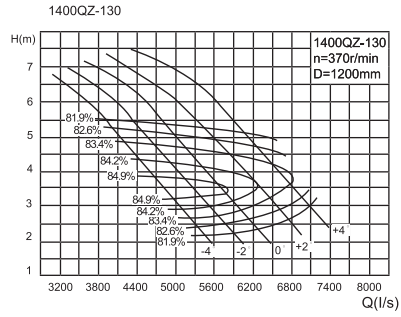

叶片安装角度 Blade angle	流量 Flow Q		扬程 Head H (m)	转速 Speed n (r/min)	功率 Power P (kW)		重量 weight (kg)	效率 Efficiency η (%)	叶轮直径 Impeller diameter (mm)
	(m³/h)	l/s			轴功率 Shaft power	电机功率 Motor power			
-4°	14116.5	3921.3	5.4	370	255.9	280	9600	81.3	1200
	18236.8	5065.8	3.0		174.1				
	19546.6	5429.6	2.2		143.1				
-2°	15746.4	4374.0	5.4	370	285.4	315	10100	81.3	
	19607.0	5446.4	3.2		200.8				
	21233.6	5898.2	2.3		162.9				
0°	17387.6	4829.9	5.3	370	309.1	355	10300	85.4	
	20906.9	5807.5	3.3		222.0				
	22705.0	6306.9	2.3		174.1				
+2°	19788.3	5496.7	5.0	370	331.1	400	11100	81.3	
	22523.7	6256.6	3.5		256.6				
	24249.9	6736.1	2.6		211.3				
+4°	21792.1	6053.4	5.0	370	364.7	400	11100	81.3	
	24111.1	6697.5	3.6		285.4				
	25535.2	7093.1	2.9		249.3				

1600QZ-70

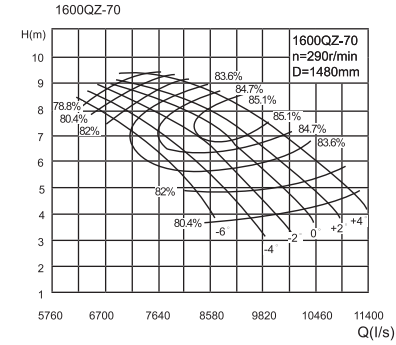

叶片安装角度 Blade angle	流量 Flow Q		扬程 Head H (m)	转速 Speed n (r/min)	功率 Power P (kW)		重量 weight (kg)	效率 Efficiency η (%)	叶轮直径 Impeller diameter (mm)
	(m³/h)	l/s			轴功率 Shaft power	电机功率 Motor power			
-6°	31227.5	8674.3	3.7	290	387.4	710	15900	81.5	1480
	29162.5	8100.7	5.4		510.8				
	25932.3	7203.4	7.2		602.1				
	23858.0	6627.2	8.0		634.2				
-4°	33323.7	9256.6	3.8	290	425.2	710	15900	81.5	
	30946.3	8596.2	5.4		542.1				
	27619.3	7672.0	7.1		625.9				
	24548.4	6819.0	8.3		678.7				
-2°	35032.5	9731.3	3.9	290	459.4	800	17900	81.5	
	32761.4	9100.4	5.4		574.6				
	28203.5	7834.3	7.6		686.9				
	25241.9	7011.6	8.6		724.7				
0°	36716.4	10199.0	4.1	290	507.5	800	17900	81.5	
	34751.4	9653.2	5.4		612.4				
	31489.9	8747.2	7.2		718.4				
	25954.2	7209.5	8.8		763.5				
+2°	37696.1	10547.0	4.4	290	551.8	900	19300	81.5	
	32839.5	9122.1	7.1		738.2				
	30402.8	8445.2	8.0		765.0				
	26494.6	7359.6	8.9		788.8				
+4°	39956.0	11098.9	4.7	290	594.0	900	19300	81.5	
	35201.2	9778.1	7.1		791.3				
	32092.9	8914.7	8.4		852.3				
	27944.2	7762.3	9.2		861.7				

1400QZ-160

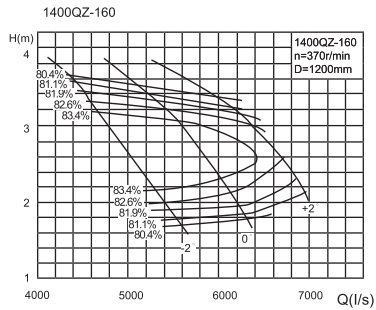

叶片安装角度 Blade angle	流量 Flow Q		扬程 Head H (m)	转速 Speed n (r/min)	功率 Power P (kW)		重量 weight (kg)	效率 Efficiency η (%)	叶轮直径 Impeller diameter (mm)
	(m³/h)	l/s			轴功率 Shaft power	电机功率 Motor power			
-2°	15960.8	4433.6	3.6	370	192.7	220	8800	81.1	1200
	18225.7	5062.7	2.6		151.6				
	19909.2	5530.3	1.8		120.2				
0°	18853.2	5237.0	3.5	370	221.3	250	9200	84.2	
	21165.2	5879.2	2.6		177.8				
	22501.2	6250.3	1.9		143.4				
+2°	24986.0	6082.2	3.3	370	242.3	280	9560	82.9	
	23634.4	6565.1	2.8		217.1				
	24934.0	6926.1	2.2		184.0				

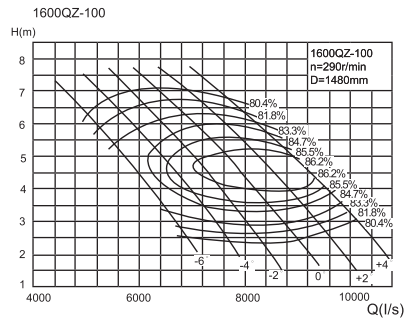

叶片安装角度 Blade angle	流量 Flow Q		扬程 Head H	转速 Speed n	功率 Power P (kW)		重量 weight	效率 Efficiency η	叶轮直径 Impeller diameter
	(m³/h)	l/s	(m)	(r/min)	轴功率 Shaft power	电机功率 Motor power	(kg)	(%)	(mm)
-6°	19837.1	5510.3	5.1	290	332.9	400	12100	82.0	1480
	21609.0	6002.5	3.9		272.3				
	23284.0	6468.0	3.1		240.5				
-4°	21059.2	5849.8	5.6		394.2	450	12500	82.0	
	24202.1	6722.8	4.0		308.6				
	26430.2	7341.7	2.8		247.4				
-2°	22540.6	6261.3	5.9		443.8	500	12800	82.0	
	26363.0	7323.1	4.1		341.9				
	28768.8	7991.3	2.8		269.3				
0°	24149.3	6708.1	6.0		483.2	560	13200	82.0	
	28523.9	7923.3	4.1		368.7				
	30836.5	8565.7	2.8		288.6				
+2°	26367.8	7324.4	6.1	536.1	630	13700	82.0		
	30252.8	8403.5	4.3	407.3					
	32658.0	9071.1	3.1	337.3					
+4°	28821.5	8005.0	5.8	558.1	630	13700	82.0		
	32413.5	9003.8	4.3	437.9					
	34387.1	9552.0	3.4	388.4					

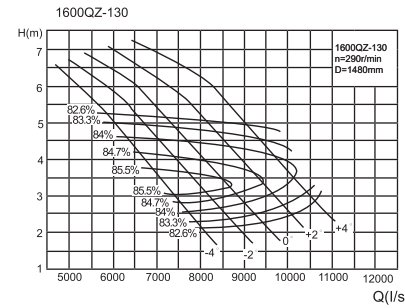

叶片安装角度 Blade angle	流量 Flow Q		扬程 Head H	转速 Speed n	功率 Power P (kW)		重量 weight	效率 Efficiency η	叶轮直径 Impeller diameter
	(m³/h)	l/s	(m)	(r/min)	轴功率 Shaft power	电机功率 Motor power	(kg)	(%)	(mm)
-4°	20754.2	5765.1	5.1	290	352.6	400	11800	81.0	1480
	26812.0	7447.8	2.8		239.8				
	28737.6	7982.7	2.0		197.2				
-2°	23150.4	6430.7	5.1		393.3	450	12200	81.0	
	28826.4	8007.3	3.0		276.6				
	31217.8	8671.6	2.1		224.4				
0°	25563.4	7101.0	5.0		426.0	500	12500	81.0	
	30737.6	8538.2	3.1		305.9				
	33381.1	9272.5	2.1		239.9				
+2°	29092.9	8081.4	4.7		456.3	560	12900	84.3	
	33114.6	9198.5	3.3		353.5				
	35652.4	9903.5	2.4		291.2				
+4°	32038.9	8899.7	4.7	502.5	630	13400	81.0		
	35448.4	9846.8	3.4	393.2					
	37542.0	10428.3	2.7	343.5					

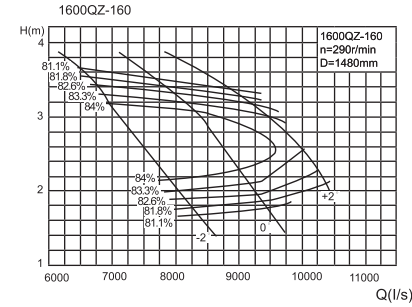

叶片安装角度 Blade angle	流量 Flow Q		扬程 Head H	转速 Speed n	功率 Power P (kW)		重量 weight	效率 Efficiency η	叶轮直径 Impeller diameter
	(m³/h)	l/s	(m)	(r/min)	轴功率 Shaft power	电机功率 Motor power	(kg)	(%)	(mm)
-2°	23462.4	6517.3	3.3	290	262.5	315	11100	81.4	1480
	26791.6	7442.1	2.4		206.6				
	29266.5	8129.6	1.7		163.7				
0°	27714.2	7698.4	3.3		301.4	355	11500	81.4	
	31112.8	8642.5	2.4		242.2				
	33076.8	9188.0	1.8		195.3				
+2°	32187.1	8940.9	3.1		330.1	400	11900	81.4	
	34742.6	9650.7	2.6		295.8				
	36653.0	10181.4	2.0		250.6				

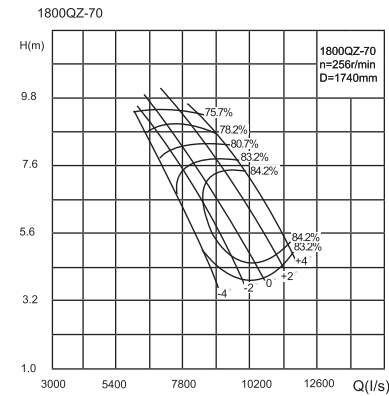

叶片安装角度 Blade angle	流量 Flow Q		扬程 Head H	转速 Speed n	功率 Power P (kW)		重量 weight	效率 Efficiency η	叶轮直径 Impeller diameter
	(m³/h)	l/s	(m)	(r/min)	轴功率 Shaft power	电机功率 Motor power	(kg)	(%)	(mm)
-4°	25607	7113	7.56	256	646.8	710	81.55		
	28958	8044	5.77		544.4				
	32004	8890	3.98		425.5				
-2°	27623	7673	7.68		698.7	800	82.76		
	31568	8769	5.95		608.2				
	34981	9717	4.22		480.2				
0°	29271	8131	7.79		750.8	900	82.77		
	33527	9313	6.10		661.9				
	37354	10376	4.41		533.8				
+2°	31932	8870	7.98		840.3	900	82.63		
	36299	10083	6.32		743.0				
	40190	11164	4.67		608.5				
+4°	32526	9035	8.13	920.8	1000	81.78			
	38318	10644	6.50	806.0					
	41994	11665	4.84	664.8					

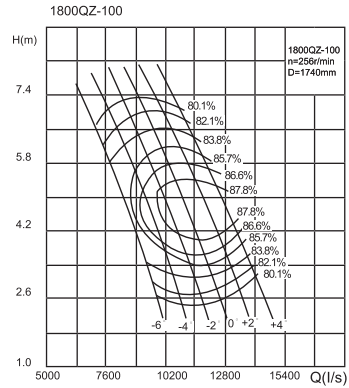

1800QZ-100

叶片安装角度 Blade angle	流量 Flow Q		扬程 Head H	转速 Speed n	功率 Power P (kW)		效率 Efficiency η	叶轮直径 Impeller diameter
	(m³/h)	l/s	(m)	(r/min)	轴功率 Shaft power	电机功率 Motor power	(%)	(mm)
-6°	28688	7969	5.55	256	512.1	560	84.67	1740
	32418	9005	3.95		409.2	560	85.35	
	35233	9787	2.63		317.1	630	79.51	
-4°	31648	8791	5.71		576.7	630	85.38	
	35499	9861	4.14		459.7	630	87.18	
	38351	10653	2.83		357.2	800	82.92	
-2°	34128	9480	5.86		634.8	710	85.79	
	38099	10583	4.32		510.4	710	87.80	
	41141	11428	3.04		406.9	800	80.69	
0°	36724	10201	6.02		701.0	800	85.99	
	40770	11325	4.51		570.4	900	87.80	
	43798	12166	3.24		457.6	900	84.50	
+2°	39179	10883	6.19	771.5	900	85.69		
	43466	12074	4.74	635.9	1100	87.80		
	46656	12960	3.47	521.9	1100	84.63		
+4°	41587	11552	6.37	864.2	1100	83.52		
	46058	12794	4.92	703.9	1300	87.80		
	49446	13735	3.72	590.9	1300	84.77		

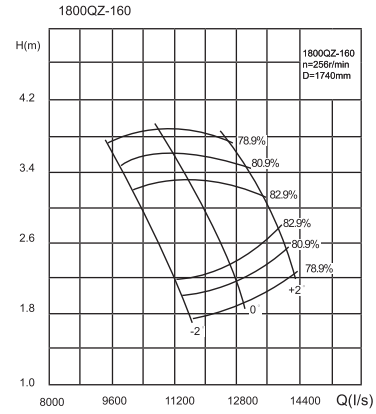

1800QZ-160

叶片安装角度 Blade angle	流量 Flow Q		扬程 Head H	转速 Speed n	功率 Power P (kW)		效率 Efficiency η	叶轮直径 Impeller diameter
	(m³/h)	l/s	(m)	(r/min)	轴功率 Shaft power	电机功率 Motor power	(%)	(mm)
-2°	36176	10049	3.26	256	392.3	450	81.79	1740
	39607	11002	2.39		311.5	450	82.90	
	41296	11471	1.91		266.2	500	80.91	
0°	41213	11448	3.41		466.6	500	82.03	
	44003	12223	2.72		393.3	500	82.90	
	45598	12666	2.25		339.3	600	82.25	
+2°	46634	12954	3.53		558.0	600	80.24	
	48550	13486	3.09		493.6	630	80.90	
	50098	13916	2.63		435.6	700	82.38	

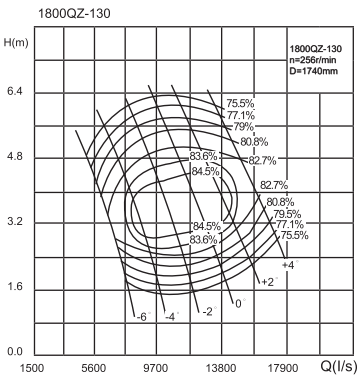

1800QZ-130

叶片安装角度 Blade angle	流量 Flow Q		扬程 Head H	转速 Speed n	功率 Power P (kW)		效率 Efficiency η	叶轮直径 Impeller diameter
	(m³/h)	l/s	(m)	(r/min)	轴功率 Shaft power	电机功率 Motor power	(%)	(mm)
-6°	21676	6021	3.93	256	288.1	330	80.49	1740
	24977	6938	2.82		232.9	330	82.28	
	27652	7681	1.79		179.6	400	75.23	
-4°	27893	7748	4.21		383.2	425	83.41	
	31835	8843	2.92		299.7	425	84.50	
	33912	9420	2.14		247.5	500	80.02	
-2°	33934	9426	4.54		502.0	560	83.70	
	37865	10518	3.30		403.0	560	84.50	
	40784	11329	2.31		311.9	700	82.28	
0°	39416	10949	4.91		634.7	710	83.09	
	43776	12160	3.74		527.7	710	84.50	
	47041	13067	2.81		432.6	800	83.18	
+2°	43844	12179	5.24	763.8	800	82.02		
	48539	13483	4.14	647.6	900	84.50		
	52081	14461	3.26	554.5	1100	83.43		
+4°	49648	13791	5.74	998.4	1100	77.72		
	54547	15152	4.70	840.5	1300	83.10		
	58079	16133	3.86	739.8	1300	82.57		

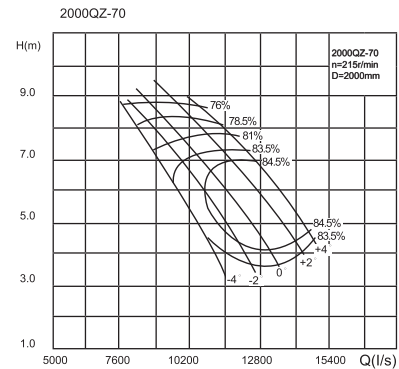

2000QZ-70

叶片安装角度 Blade angle	流量 Flow Q		扬程 Head H	转速 Speed n	功率 Power P (kW)		效率 Efficiency η	叶轮直径 Impeller diameter
	(m³/h)	l/s	(m)	(r/min)	轴功率 Shaft power	电机功率 Motor power	(%)	(mm)
-4°	32494	9026	7.02	215	759.8	800	81.78	2000
	37714	10476	4.97		609.2	800	83.81	
	40734	11315	3.67		496.9	900	81.94	
-2°	35150	9764	7.11		819.1	900	83.09	
	41404	11501	5.06		676.2	900	84.50	
	44492	12359	3.89		562.4	1100	83.96	
0°	37325	10368	7.18		878.2	1000	83.19	
	44248	12291	5.14		734.1	1000	84.50	
	47498	13194	4.09		526.6	1100	84.47	
+2°	40867	11352	7.32		979.2	1100	83.23	
	48139	13372	5.26		817.0	1100	84.50	
	51073	14187	4.34		715.5	1300	84.36	
+4°	43632	12120	7.43	1068.4	1300	82.71		
	50850	14125	5.35	877.5	1200	84.50		
	53330	14814	4.50	781.7	1300	83.72		

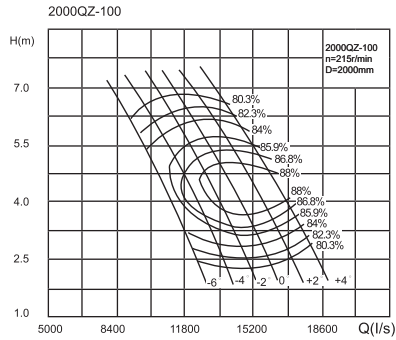

2000QZ-100

叶片安装角度 Blade angle	流量 Flow Q		扬程 Head H	转速 Speed n	功率 Power P (kW)		效率 Efficiency η	叶轮直径 Impeller diameter
	(m³/h)	l/s	(m)	(r/min)	轴功率 Shaft power	电机功率 Motor power	(%)	(mm)
-6°	34700	9639	5.64	215	645.1	710	82.75	2000
	40288	11191	3.96		505.6	710	86.09	
	44420	12339	2.57		384.3	80.81		
-4°	38588	10719	5.73	215	749.8	800	84.37	2000
	44410	12336	4.07		560.2	800	87.81	
	48622	13506	2.68		425.7	83.33		
-2°	41954	11654	5.80	215	783.0	900	84.75	2000
	47891	13303	4.16		616.5	900	88.00	
	52380	14550	2.79		475.0	83.72		
0°	45443	12623	5.89	215	856.3	900	85.20	2000
	54541	14317	4.26		680.1	900	88.00	
	56016	15560	2.90		527.1	83.94		
+2°	48744	13540	5.98	215	939.6	1000	84.55	2000
	55242	15345	4.37		748.2	1000	88.00	
	59655	16657	3.03		592.2	83.62		
+4°	52063	14462	6.08	215	1038.4	1100	83.02	2000
	58842	16345	4.49		818.5	1100	88.00	
	63889	17747	3.17		661.9	83.36		

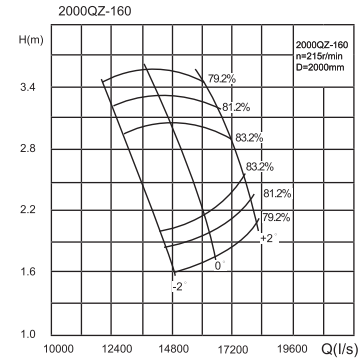

2000QZ-160

叶片安装角度 Blade angle	流量 Flow Q		扬程 Head H	转速 Speed n	功率 Power P (kW)		效率 Efficiency η	叶轮直径 Impeller diameter
	(m³/h)	l/s	(m)	(r/min)	轴功率 Shaft power	电机功率 Motor power	(%)	(mm)
-2°	45184	12551	3.15	215	478.2	560	81.13	2000
	50022	13895	2.28		373.3	560	83.20	
	52585	14607	1.75		309.4	81.05		
0°	51343	14262	3.32	215	571.7	630	81.14	2000
	56214	15615	2.46		452.4	630	83.20	
	58594	16276	1.93		380.6	81.03		
+2°	58140	16150	3.42	215	679.4	710	79.68	2000
	62694	17415	2.67		547.5	710	83.20	
	64847	18013	2.14		468.8	80.68		

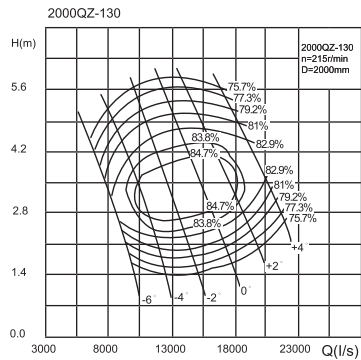

2000QZ-130

叶片安装角度 Blade angle	流量 Flow Q		扬程 Head H	转速 Speed n	功率 Power P (kW)		效率 Efficiency η	叶轮直径 Impeller diameter
	(m³/h)	l/s	(m)	(r/min)	轴功率 Shaft power	电机功率 Motor power	(%)	(mm)
-6°	25056	6960	4.18	215	367.8	400	77.59	2000
	31133	9648	2.78		281.4	400	83.73	
	35186	9774	1.65		210.4	75.39		
-4°	33396	9277	4.32	215	480.5	560	81.81	2000
	35910	10975	2.95		374.6	560	84.70	
	43596	12110	1.84		277.3	79.03		
-2°	41785	11607	4.50	215	616.8	710	83.08	2000
	47722	13256	3.15		484.0	710	84.70	
	52088	14469	2.08		358.9	82.15		
0°	49338	13705	4.70	215	763.1	800	82.77	2000
	55991	15553	3.40		612.1	800	84.70	
	60936	16924	2.36		477.5	82.18		
+2°	55613	15448	4.89	215	901.8	1000	82.11	2000
	62870	17464	3.63		734.7	1000	84.70	
	68292	18970	2.64		603.3	81.31		
+4°	64040	17789	5.17	215	1146.5	1200	78.76	2000
	71600	19889	3.97		923.2	1200	83.87	
	76943	21373	3.00		794.1	79.11		

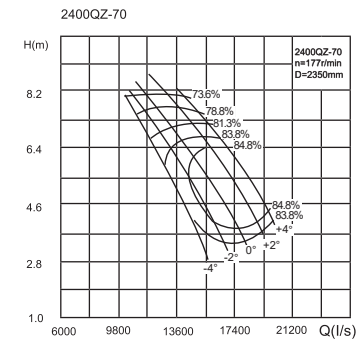

2400QZ-70

叶片安装角度 Blade angle	流量 Flow Q		扬程 Head H	转速 Speed n	功率 Power P (kW)		效率 Efficiency η	叶轮直径 Impeller diameter
	(m³/h)	l/s	(m)	(r/min)	轴功率 Shaft power	电机功率 Motor power	(%)	(mm)
-4°	46886	13024	5.57	177	847.3	900	83.97	2350
	50227	13952	4.62		752.2	900	84.11	
	54004	15001	3.49		623.0	82.42		
-2°	52078	14466	5.45	177	912.8	1000	84.80	2350
	55872	15520	4.52		812.1	1000	84.80	
	59317	16492	3.59		689.9	84.21		
0°	55544	15429	5.52	177	984.8	1100	84.80	2350
	59785	16607	4.60		883.6	1100	84.80	
	63778	17716	3.68		757.5	84.48		
+2°	60667	16852	5.62	177	1095.1	1200	84.80	2350
	64991	18053	4.71		983.3	1200	84.80	
	69041	19178	3.80		852.5	83.84		
+4°	64422	17895	5.70	177	1179.2	1300	84.80	2350
	68537	19038	4.79		1054.4	1300	84.80	
	72288	20080	3.88		928.2	82.26		

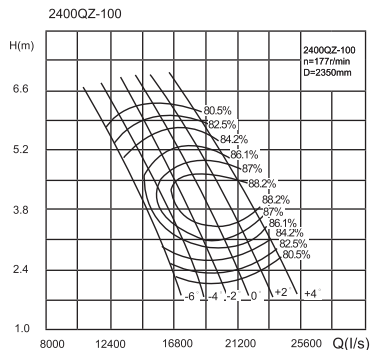

2400QZ-100

叶片安装角度 Blade angle	流量 Flow Q		扬程 Head H	转速 Speed n (r/min)	功率 Power P (kW)		效率 Efficiency η (%)	叶轮直径 Impeller diameter (mm)
	(m³/h)	l/s	(m)		轴功率 Shaft power	电机功率 Motor power		
-6°	49590	13775	4.57	177	720.6	800	85.75	2350
	54698	15194	3.45		599.6	800	85.85	
	58619	16283	2.52		490.9	82.04		
-4°	54936	15260	4.66		805.7	900	86.54	
	60210	16725	3.55		665.5	900	87.52	
	64199	17833	2.63		546.3	84.07		
-2°	59411	16503	4.74		878.8	1000	87.25	
	64890	18025	3.64		729.5	1000	88.20	
	69156	19210	2.73		606.6	84.66		
0°	64213	17837	4.83		964.0	1000	87.59	
	69772	19381	3.74		805.8	1000	88.20	
	74009	20558	2.83		670.3	85.17		
+2°	68832	19120	4.92		1054.5	1100	87.49	
	74732	20759	3.85		888.3	1100	88.20	
	79214	22004	2.95		753.4	84.58		
+4°	73408	20391	5.02	1164.6	1300	86.18		
	79610	22115	3.96	974.4	1300	88.20		
	84402	23445	3.08	840.7	84.28			

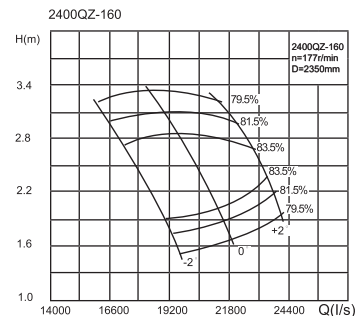

2400QZ-160

叶片安装角度 Blade angle	流量 Flow Q		扬程 Head H	转速 Speed n (r/min)	功率 Power P (kW)		效率 Efficiency η (%)	叶轮直径 Impeller diameter (mm)
	(m³/h)	l/s	(m)		轴功率 Shaft power	电机功率 Motor power		
-2°	61747	17152	2.75	177	566.9	630	83.09	2350
	65844	18290	2.23		478.2	630	83.50	
	69556	19321	1.70		392.3	82.04		
0°	70054	19459	2.91		669.9	710	82.86	
	74149	20597	2.39		579.2	710	83.50	
	77605	21557	1.87		481.5	82.09		
+2°	78440	21789	3.09		818.3	900	80.66	
	82724	22979	2.59		698.5	900	83.50	
	85946	23874	2.07		593.8	81.49		

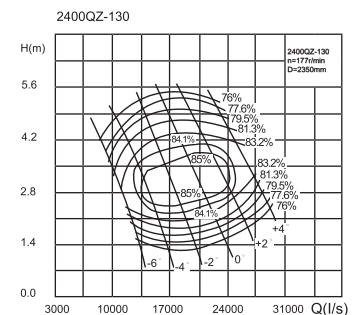

2400QZ-130

叶片安装角度 Blade angle	流量 Flow Q		扬程 Head H	转速 Speed n (r/min)	功率 Power P (kW)		效率 Efficiency η (%)	叶轮直径 Impeller diameter (mm)
	(m³/h)	l/s	(m)		轴功率 Shaft power	电机功率 Motor power		
-6°	32879	9133	3.96	177	458.3	500	77.41	2350
	41094	11415	2.65		352.4	500	84.23	
	46001	12778	1.71		280.0	76.73		
-4°	43974	12215	4.09		599.8	630	81.66	
	52247	14513	2.81		469.9	630	85.00	
	57197	15888	1.89		362.7	81.03		
-2°	55231	15342	4.25		769.1	800	83.22	
	63205	17557	2.99		606.5	800	85.00	
	68447	19013	2.10		469.7	83.21		
0°	65218	18116	4.43		951.7	1000	82.72	
	74164	20601	3.22		764.7	1000	85.00	
	80107	22252	2.35		616.3	83.33		
+2°	73458	20430	4.60		1124	1200	82.07	
	83318	23144	3.43		916.3	1200	75.00	
	89842	24956	2.60		768.5	82.76		

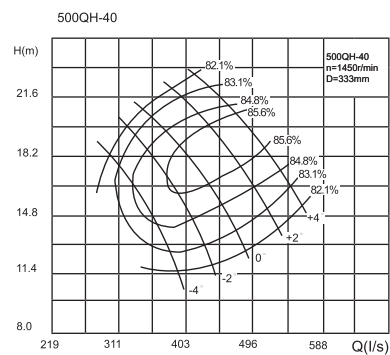

500QH-40

叶片安装角度 Blade angle	流量 Flow Q		扬程 Head H	转速 Speed n (r/min)	功率 Power P (kW)		效率 Efficiency η (%)	叶轮直径 Impeller diameter (mm)
	(m³/h)	l/s	(m)		轴功率 Shaft power	电机功率 Motor power		
-4°	932	259	19.58	1450	61.64	75	80.62	333
	1271	353	15.07		61.11	75	85.30	
	1310	364	14.14		61.98	84.85		
-2°	1159	322	19.89		79.77	90	82.06	
	1343	373	17.21		76.55	90	85.55	
	1483	412	14.46		71.66	84.86		
0°	1314	365	20.15		89.86	110	83.52	
	1512	420	17.52		87.57	110	85.60	
	1656	460	14.82		82.47	84.37		
+2°	1523	423	20.54		104.4	132	84.98	
	1602	445	19.50		103.4	132	85.60	
	1843	512	15.25		95.58	83.29		
+4°	1688	469	20.89		117.2	108.6	85.25	
	1764	490	19.86		116.1	132	85.60	
	2009	558	15.68		108.6	82.22		

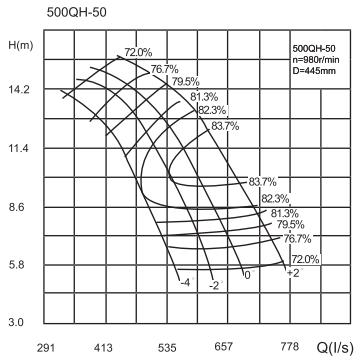

500QH-50

叶片安装角度 Blade angle	流量 Flow Q		扬程 Head H	转速 Speed n	功率 Power P (kW)		效率 Efficiency η	叶轮直径 Impeller diameter
	(m³/h)	l/s	(m)	(r/min)	轴功率 Shaft power	电机功率 Motor power	(%)	(mm)
-4°	1620	450	11.1	980	62.9	75	81.27	445
	1731	481	9.72		57.9		82.32	
	1948	541	6.36		46.0		76.28	
	1854	515	11.4		72.2		82.75	
-2°	1962	545	9.98		66.4	90	83.70	
	2171	603	6.64		53.3		76.57	
	2027	563	11.6		79.1		83.60	
	2146	596	10.2		74.1		83.70	
0°	2376	660	6.92		60.4	110	77.05	
	2264	629	11.9		91.0		83.70	
	2394	665	10.6		85.5		83.70	
	2650	736	7.34		70.6		78.04	

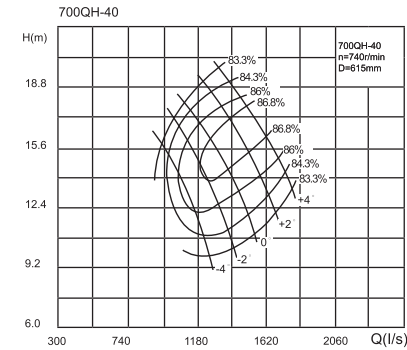

700QH-40

叶片安装角度 Blade angle	流量 Flow Q		扬程 Head H	转速 Speed n	功率 Power P (kW)		效率 Efficiency η	叶轮直径 Impeller diameter
	(m³/h)	l/s	(m)	(r/min)	轴功率 Shaft power	电机功率 Motor power	(%)	(mm)
-4°	2923	812	16.98	740	165.5	210	81.69	615
	3697	1027	14.76		174.5		85.25	
	4122	1145	12.45		162.1		86.25	
	3661	1017	17.25		207.1		83.16	
-2°	4241	1178	15		200	250	86.7	
	4673	1298	12.72		187.7	86.25		
	4154	1154	17.46		233.7	84.62		
	4763	1323	15.27		228.3	280	86.8	
0°	5216	1449	13.02		215.5	315	85.86	
	4813	1337	17.8		271.1		86.1	
	5364	1490	15.61		262.9		86.8	
	5803	1612	13.38		249.5		84.82	
+2°	5339	1483	18.09	304.8	355	86.37		
	5890	1636	15.94	294.7		86.8		
	6340	1761	13.75	284.2		83.56		

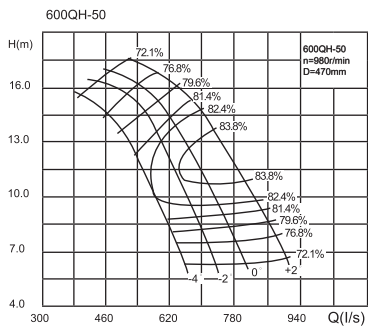

600QH-50

叶片安装角度 Blade angle	流量 Flow Q		扬程 Head H	转速 Speed n	功率 Power P (kW)		效率 Efficiency η	叶轮直径 Impeller diameter
	(m³/h)	l/s	(m)	(r/min)	轴功率 Shaft power	电机功率 Motor power	(%)	(mm)
-4°	1602	445	14.3	980	84.3	110	77.0	470
	2088	580	10.2		73.1		82.5	
	2304	640	7.42		62.9		77.0	
	1710	475	15.2		95.6		77.0	
-2°	2322	645	11.0		87.2	132	83.0	
	2574	751	7.5		71.0		77.0	
	1847	513	15.9		108.0		77.0	
	2459	683	12.0		99.6		83.9	
0°	2844	790	7.65		80.0	160	77.0	
	2052	570	16.8		126.8		77.0	
	2808	780	12.0		113.7		83.9	
	3186	885	7.9		82.6		77.0	

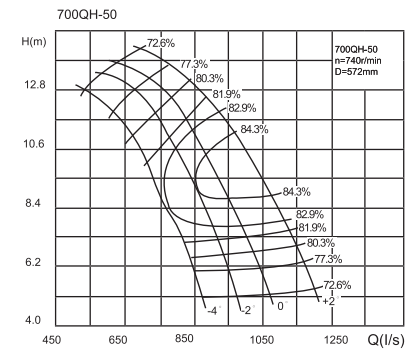

700QH-50

叶片安装角度 Blade angle	流量 Flow Q		扬程 Head H	转速 Speed n	功率 Power P (kW)		效率 Efficiency η	叶轮直径 Impeller diameter
	(m³/h)	l/s	(m)	(r/min)	轴功率 Shaft power	电机功率 Motor power	(%)	(mm)
-4°	2531	703	10.3	740	90.9	110	81.58	572
	2725	757	8.96		83.5		82.9	
	3060	850	5.89		66.6		76.82	
	2902	806	10.6		105.0		82.91	
-2°	3092	859	9.21		95.7	132	84.3	
	3420	950	6.16		77.0		77.64	
	3164	879	10.8		115.0		83.93	
	3366	935	9.42		106.6		84.3	
0°	3733	1037	6.42		86.1	160	78.86	
	3535	982	11.1		131.3		84.3	
	3758	1044	9.74		123.0		84.3	
	4165	1157	6.81		102.0		78.81	

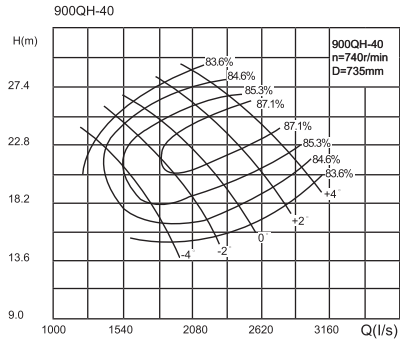

900QH-40

叶片安装角度 Blade angle	流量 Flow Q		扬程 Head H (m)	转速 Speed n (r/min)	功率 Power P (kW)		效率 Efficiency η (%)	叶轮直径 Impeller diameter (mm)
	(m³/h)	l/s			轴功率 Shaft power	电机功率 Motor power		
-4°	5652	1570	23.5	740	453.5		83.07	735
	6296	1749	21.6		450.6	500	85.46	
	7387	2052	16.3		399.3		85.17	
-2°	6678	1855	23.9	740	531.7		85.14	735
	7232	2009	22.0		517.6	560	87.04	
	8348	2319	16.7		465.0		85.15	
0°	7509	2086	24.3	740	597.7		86.53	735
	8096	2249	22.4		589.3		87.2	
	9277	2577	17.3		535.3	710	84.79	
+2°	8571	2591	24.9	740	692.6		87.17	735
	9115	2532	23.0		680.4		87.2	
	10274	2854	17.9		619.9		84.0	
+4°	9464	2629	25.4	740	780.4		87.2	735
	10011	2781	23.5		765.0	800	87.2	
	11185	3170	18.5		703.1		83.44	

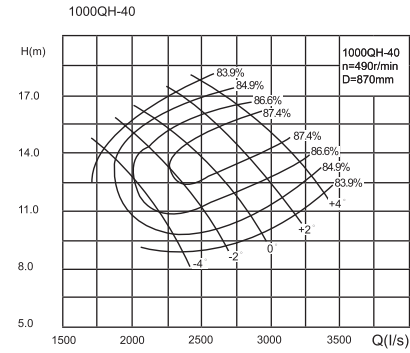

1000QH-40

叶片安装角度 Blade angle	流量 Flow Q		扬程 Head H (m)	转速 Speed n (r/min)	功率 Power P (kW)		效率 Efficiency η (%)	叶轮直径 Impeller diameter (mm)
	(m³/h)	l/s			轴功率 Shaft power	电机功率 Motor power		
-4°	5310	1475	15.4	490	271.6		82.06	870
	6995	1943	13.39		297.7	315	85.72	
	7912	2206	10.89		272.6		86.50	
-2°	6880	1911	15.67	490	351.8		83.52	870
	8021	2228	13.61		340.9	400	87.27	
	8989	2497	11.15		315.8		86.46	
0°	7808	2169	15.86	490	397.6		84.92	870
	9011	2503	13.85		389.2	450	87.40	
	10030	2786	11.43		363.0		86.01	
+2°	9072	2520	16.17	490	462.2		86.45	870
	10152	2820	14.16		448.3	500	87.40	
	11146	3096	11.76		420.4		84.95	
+4°	10069	2797	16.44	490	519.9		86.73	870
	11149	3097	14.46		502.6	560	87.40	
	12161	3378	12.1		477.8		83.90	

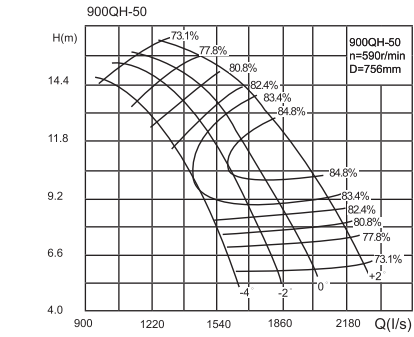

900QH-50

叶片安装角度 Blade angle	流量 Flow Q		扬程 Head H (m)	转速 Speed n (r/min)	功率 Power P (kW)		效率 Efficiency η (%)	叶轮直径 Impeller diameter (mm)
	(m³/h)	l/s			轴功率 Shaft power	电机功率 Motor power		
-4°	4597	1277	12.3	590	196.1		81.41	756
	5083	1412	10.2		176.9	220	83.39	
	5731	1592	6.59		140.1		76.43	
-2°	5296	1471	12.5	590	226.6		82.88	756
	5767	1602	10.5		202.8	250	84.62	
	6408	1780	6.88		161.9		77.17	
0°	5782	1606	12.7	590	248.2		83.91	756
	6289	1747	10.7		225.4	280	84.8	
	6995	1943	7.17		181.3		78.18	
+2°	6469	1797	13.0	590	282.8		84.39	756
	7024	1951	11.1		260.1	315	84.8	
	7805	2168	7.6		208.9		78.96	

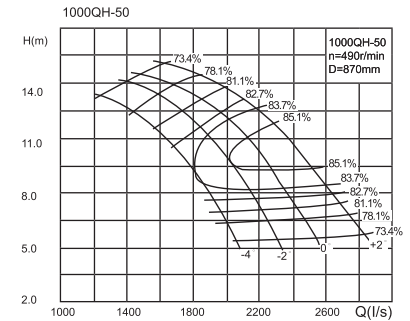

1000QH-50

叶片安装角度 Blade angle	流量 Flow Q		扬程 Head H (m)	转速 Speed n (r/min)	功率 Power P (kW)		效率 Efficiency η (%)	叶轮直径 Impeller diameter (mm)
	(m³/h)	l/s			轴功率 Shaft power	电机功率 Motor power		
-4°	5486	1524	11.99	490	225.0		79.63	870
	6354	1765	9.65		200.0	250	83.57	
	7096	1971	6.81		162.7		80.97	
-2°	6430	1786	12.17	490	260.9		81.72	870
	6800	1889	9.85		228.4	280	85.09	
	7960	2211	7.02		188.6		80.80	
0°	6419	1783	13.47	490	296.1		79.54	870
	7920	2200	10.01		254.0	355	85.10	
	8708	2419	7.23		210.6		81.42	
+2°	7257	2016	13.60	490	332.4		81.23	870
	8856	2460	10.27		291.1	400	85.10	
	9734	2704	7.53		244.9		81.57	

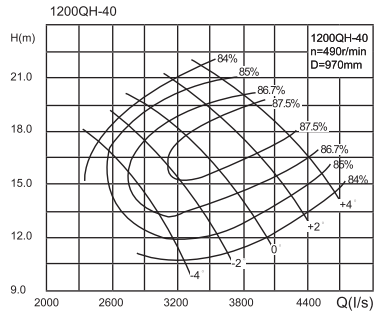

1200QH-40

叶片安装角度 Blade angle	流量 Flow Q		扬程 Head H	转速 Speed n	功率 Power P (kW)		效率 Efficiency η	叶轮直径 Impeller diameter
	(m³/h)	l/s	(m)	(r/min)	轴功率 Shaft power	电机功率 Motor power	(%)	(mm)
-4°	9061	2517	17.16	490	501.3	560	84.53	970
	10256	2849	14.84		475.4		87.24	
	11290	3136	12.02		434.4		85.14	
-2°	9918	2755	18.39		585.4	630	84.89	
	11473	3187	15.55		555.7		87.50	
	12780	3550	12.31		504.0		85.05	
0°	10476	2910	19.54		660.3	710	84.46	
	12208	3391	17.09		649.7		87.50	
	14245	3957	12.62		579.4		84.56	
+2°	12125	3368	20.06		773.1	800	85.73	
	13691	3803	17.63		751.6		87.50	
	15278	4244	14.27		698.9		85.00	
+4°	13399	3722	20.52	872.6	900	85.85		
	14969	4158	18.14	845.5		87.50		
	16592	4609	14.83	799.0		84.09		

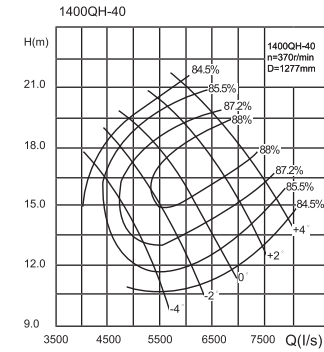

1400QH-40

叶片安装角度 Blade angle	流量 Flow Q		扬程 Head H	转速 Speed n	功率 Power P (kW)		效率 Efficiency η	叶轮直径 Impeller diameter
	(m³/h)	l/s	(m)	(r/min)	轴功率 Shaft power	电机功率 Motor power	(%)	(mm)
-4°	15156	4210	17.18	370	839.7	900	84.51	1277
	17374	4826	14.90		805.1		87.62	
	19228	5314	12.10		737.7		86.95	
-2°	17730	4925	17.44		971.1	1100	86.73	
	19786	5496	15.17		929.2		88.00	
	21744	6040	12.41		855.5		85.94	
0°	18288	5080	19.00		1108.7	1200	85.40	
	20941	5817	16.81		1089.9		88.00	
	23796	6610	13.36		1004.6		86.24	
+2°	21287	5913	19.35		1290.7	1400	86.96	
	23652	6570	17.17		1257.4		88.00	
	26330	7314	13.89		1167.4		85.36	
+4°	23641	6567	19.67	1451.7	1500	87.27		
	25996	7221	17.51	1409.9		88.00		
	28634	7954	14.42	1331.6		84.49		

1200QH-50

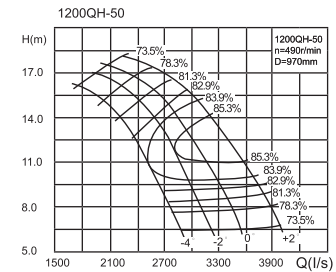

叶片安装角度 Blade angle	流量 Flow Q		扬程 Head H	转速 Speed n	功率 Power P (kW)		效率 Efficiency η	叶轮直径 Impeller diameter
	(m³/h)	l/s	(m)	(r/min)	轴功率 Shaft power	电机功率 Motor power	(%)	(mm)
-4°	7380	5050	15.00	490	383.8	450	78.61	970
	8863	2462	11.71		337.6		83.77	
	9738	2705	8.85		284.5		82.59	
-2°	8730	2425	15.20		445.5	500	81.14	
	10105	2807	11.92		384.9		85.30	
	10951	3042	9.08		327.8		82.67	
0°	9270	2575	15.88		495.2	560	81.03	
	11059	3072	12.10		427.6		85.30	
	11984	3329	9.30		365.9		82.97	
+2°	10465	2907	16.10		556.4	630	82.50	
	12380	3439	12.38		489.8		85.30	
	13414	3726	9.62		423.1		83.13	

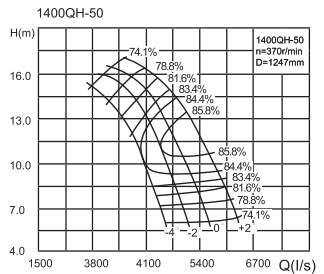

1400QH-50

叶片安装角度 Blade angle	流量 Flow Q		扬程 Head H	转速 Speed n	功率 Power P (kW)		效率 Efficiency η	叶轮直径 Impeller diameter
	(m³/h)	l/s	(m)	(r/min)	轴功率 Shaft power	电机功率 Motor power	(%)	(mm)
-4°	10825	3007	14.71	365	564.5	630	76.87	1247
	14051	3903	10.81		490.8		84.35	
	15505	4307	7.90		406.9		82.06	
-2°	12604	3501	15.27		666.7	710	78.65	
	15840	4400	11.31		569.2		85.77	
	17406	4835	8.14		470.8		81.97	
0°	13990	3886	15.40		734.0	800	80.00	
	17320	4811	11.50		632.3		85.80	
	19040	5289	8.36		525.6		82.53	
+2°	15851	4403	15.61		824.6	900	81.78	
	19372	5381	11.78		724.7		85.80	
	21290	5914	8.70		610.9		82.64	

● 安装型式 Installation type

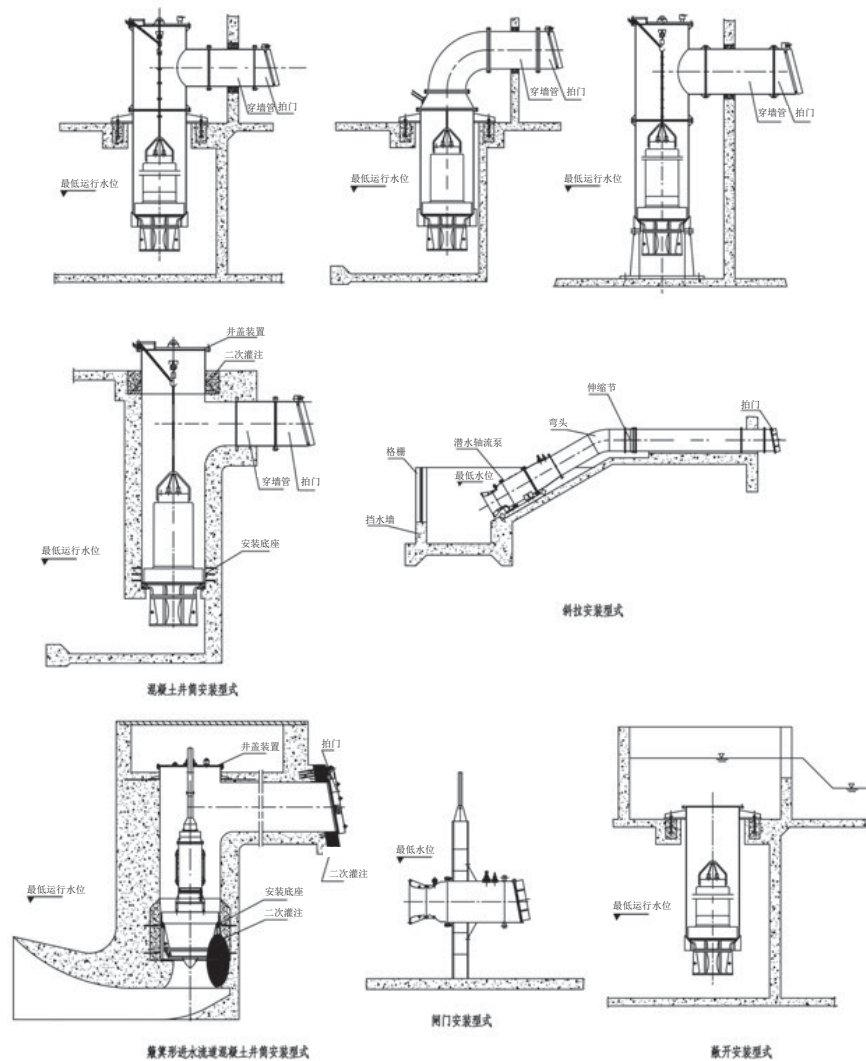

● 安装尺寸 Installation dimension

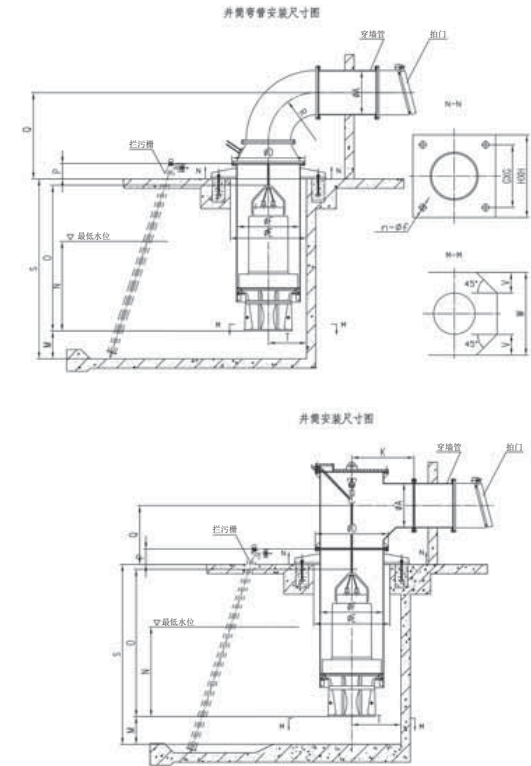

- 注: Note:
- ①表中尺寸为泵的安装尺寸、泵站设计的水力控制尺寸, 其中泵站设计的水力尺寸为参考值。
The dimensions in the table are the installation dimensions of the pump and the hydraulic control dimensions for the design of pump station, of which the hydraulic dimensions are reference values.
 - ② 尺寸A依据泵流量确定, 以控制流速, 减少水力损失, 表中尺寸为参考值, 如需要, 可适当加大; 尺寸S、Q依据泵站具体条件确定。
The dimension A is determined according to the pump flow to control the flow rate and reduce hydraulic loss. The dimensions in the table are reference values and can be appropriately increased if necessary. Dimensions S and Q are determined according to the specific conditions of the pump station.
 - ③ 泵中心距后池壁不大于尺寸T;
The distance between the center of the pump and the rear tank wall shall not be more than dimension T;
 - ④ 同池内两泵中心距不小于尺寸Z。
The center distance between two pumps in the same tank shall not be less than dimension Z.

钢制井筒式安装尺寸表（一） Dimension table of steel well bore installation (1)

序号 No.	型号 Model	φA	φD	φE	φF	G	H	n-φf	R	K	M	N	O	P	Z	T	W	V	轴向水推力 Axial Hydral Thrust (N)
1	350QZ-70G											720	2300						6800
2	350QZ-70D	400	755	800	600	1150	1350	4-M24*400	600	750	290	720	1733	200	1400	400	1400	350	3500
3	350QZ-100											710	1733						5500
4	350QZ-130											800	1733						4800
5	500QH-40											780	2850						8800
6	500QH-50											810	2900						10800
7	500QZ-70											1120	2553						15700
8	500QZ-100G											810	2080	200	1800	540	1800	450	12700
9	500QZ-100D	500	975	1050	800	1350	1600	4-M30*400	900	900	430	810	2013						7200
10	500QZ-130G											1200	2080						11000
11	500QZ-130D											1120	2015						6300
12	600QH-40											800	2880						16600
13	600QH-50											880	2950						24100
14	600QZ-70											880	2570						19900
15	600QZ-100	700	1175	1225	1000	1600	1850	4-M30*500	1000	1000	530	880	2570	220	2200	660	2200	550	16100
16	600QZ-130											880	2570						14000
17	600QZ-160											880	2570						14000
18	700QH-40											900	2960						28600
19	700QH-50											960	3000						34200
20	700QZ-70G											1400	2850						28300
21	700QZ-70D											1400	2850	220	2400	720	2400	600	28300
22	700QZ-100	800	1305	1365	1100	1700	2000	4-M36*500	1250	1000	580	960	2570						22900
23	700QZ-130											1480	2570						19900
24	700QZ-160											1100	2570						13900

钢制井筒式安装尺寸表（二） Dimension table of steel well bore installation (2)

序号 No.	型号 Model	φA	φD	φE	φF	G	H	n-φf	R	K	M	N	O	P	Z	T	W	V	轴向水推力 Axial Hydral Thrust (N)
25	800QZ-70G											1120	3100						40200
26	800QZ-70D	900	1405	1450	1200	1900	2150	4-M36*500	1450	1100	670	1120	2900	260	2800	840	2800	700	33300
27	800QZ-100											1120	2900						26900
28	800QZ-130											1120	2900						23400
29	800QZ-160											1120	2900						16400
30	900QH-40											1200	3600						48200
31	900QH-50											1360	3800						56100
32	900QZ-70G											1520	3600						56300
33	900QZ-70D											1360	3700						49800
34	900QZ-100G											1360	3370						45600
35	900QZ-100D	1000	1520	1600	1300	2000	2250	4-M36*500	1600	1200	820	1360	3500	300	3400	1020	3400	850	40400
36	900QZ-130G											1600	3000						39600
37	900QZ-130D											1360	3100						35100
38	900QZ-160G											1360	3000						27800
39	900QZ-160D											1360	3100						24600
40	1000QH-40											1280	3960						53600
41	1000QH-50											1390	4200						66200
42	1000QZ-70											1390	3900						54800
43	1000QZ-100	1200	1630	1700	1400	2050	2300	4-M36*500	1800	1300	840	1390	3300	300	3480	1040	3480	870	44300
44	1000QZ-130											1390	3300						38500
45	1000QZ-160											1390	3300						27000
46	1200QH-40											1880	4000						88000
47	1200QH-50											2080	4600						94100
48	1200QZ-70											2740	4300						77800
49	1200QZ-100	1400	1830	1900	1600	2200	2500	4-M36*500	2000	1500	910	2520	3800	300	3800	1140	3800	950	63000
50	1200QZ-130											2830	3800						54700
51	1200QZ-160											2910	3800						38400

混凝土预制井筒式安装 Concrete prefabricated well bore installation

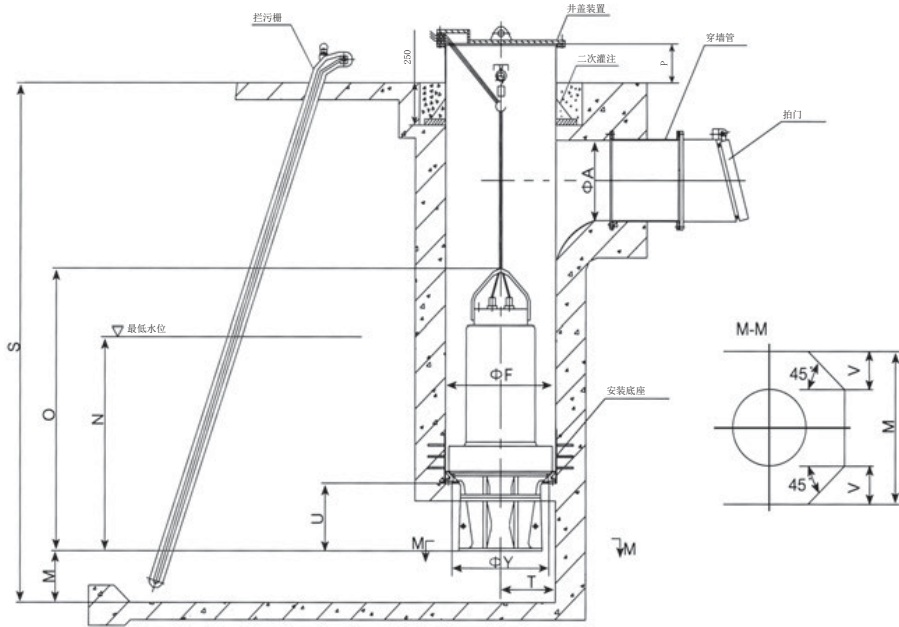

注:

Note:

① 表中尺寸为泵的安装尺寸、泵站设计的水力控制尺寸，其中泵站设计的水力尺寸为参考值。

The dimensions in the table are the installation dimensions of the pump and the hydraulic control dimensions for the design of pump station, of which the hydraulic dimensions are reference values.

② 尺寸A依据泵流量确定，以控制流速，减少水力损失，表中尺寸为参考值，如需要，可适当加大；尺寸S依据泵站具体条件确定。

The dimension A is determined according to the pump flow to control the flow rate and reduce hydraulic loss. The dimensions in the table are reference values and can be appropriately increased if necessary. Dimension S is determined according to the specific conditions of the pump station.

③ 泵中心距后池壁不大于尺寸T；

The distance between the center of the pump and the rear tank wall shall not be more than dimension T;

④ 同池内两泵中心距不小于尺寸Z。

The center distance between two pumps in the same tank shall not be less than dimension Z.

混凝土预制井筒式安装尺寸表（一）

Dimension table of concrete prefabricated well bore installation (1)

序号 No.	型号 Model	轴向往水推力 Axial water thrust (N)	φY	U	V	W	T	Z	P	O	N	M	φF	φA	型号 Model
1	350QZ-70G	6800							200	2300	720	290	600	400	350QZ-70G
2	350QZ-70D	3500	500	360	350	1400	400	1400	200	1733	720	290	600	400	350QZ-70D
3	350QZ-100	5500								1733	710				350QZ-100
4	350QZ-130	4800								1733	800				350QZ-130
5	500QH-40	8800								2850	780				500QH-40
6	500QH-50	10800								2900	810				500QH-50
7	500QZ-70	15700								2553	1120	430	800	500	500QZ-70
8	500QZ-100G	12700	680	540	450	1800	540	1800	200	2080	1120	430	800	500	500QZ-100G
9	500QZ-100D	7200								2013	810				500QZ-100D
10	500QZ-130G	11000								2080	1200				500QZ-130G
11	500QZ-130D	6300								2015	810				500QZ-130D
12	600QH-40	16600								2880	800				600QH-40
13	600QH-50	24100								2900	880				600QH-50
14	600QZ-70	19900								2570	880	530	1000	700	600QZ-70
15	600QZ-100	16100	880	660	550	2200	660	2200	220	2570	880	530	1000	700	600QZ-100
16	600QZ-130	14000								2570	880				600QZ-130
17	600QZ-160	14000								2570	880				600QZ-160
18	700QH-40	28600								2960	900				700QH-40
19	700QH-50	34200								3000	960				700QH-50
20	700QZ-70G	28300								2850	1400				700QZ-70G
21	700QZ-70D	28300	950	720	600	2400	720	2400	220	2850	1400	580	1100	800	700QZ-70D
22	700QZ-100	22800								2570	860				700QZ-100
23	700QZ-130	19900								2570	1480				700QZ-130
24	700QZ-160	13900								2570	1100				700QZ-160

混凝土预制井筒式安装尺寸表（二）

Dimension table of concrete prefabricated well bore installation (2)

序号 No.	型号 Model	φA	φF	M	N	O	P	Z	T	W	V	U	φY	轴向水推力 Axial Hydr thrust (N)
26	800QZ-70G				1120	3100								40200
27	800QZ-70D		1200	670	1120	2900	260	280	840	2800	700	940	1050	33300
28	800QZ-100	900			1120	2900								28900
29	800QZ-130				1120	2900								23400
30	800QZ-160				1120	2900								16400
31	900QH-40				1200	3600								48200
32	900QH-50				1360	3800								56100
33	900QZ-70G				1520	3600								56300
34	900QZ-70D				1360	3700								49900
35	900QZ-100G				1360	3370								45600
36	900QZ-100D	1000	1300	820	1360	3500	300	3400	1020	3400	850	1020	1150	40400
37	900QZ-130G				1500	3000								39600
38	900QZ-130D				1360	3100								35100
39	900QZ-160G				1360	3000								27800
40	900QZ-160D				1360	3100								24600
41	1000QH-40				1280	3900								53800
42	1000QH-50				1390	4200								66200
43	1000QZ-70				1390	3900								54800
44	1000QZ-100	1200	1400	840	1390	3300	300	3480	1040	3480	670	1040	1250	44300
45	1000QZ-130				1390	3300								38500
46	1000QZ-160				1390	3300								27000
47	1200QH-40				1880	4000								88000
48	1200QH-50				2080	4600								94100
49	1200QZ-70				2740	4300								77800
50	1200QZ-100	1400	1600	910	2520	3800	300	3600	1140	3800	950	1140	1420	63000
51	1200QZ-130				2830	3800								54700
52	1200QZ-160				2910	3800								38400

簸箕形进水水道混凝土井筒安装尺寸图

Installation dimension drawing of concrete well bore with dustpan inlet channel

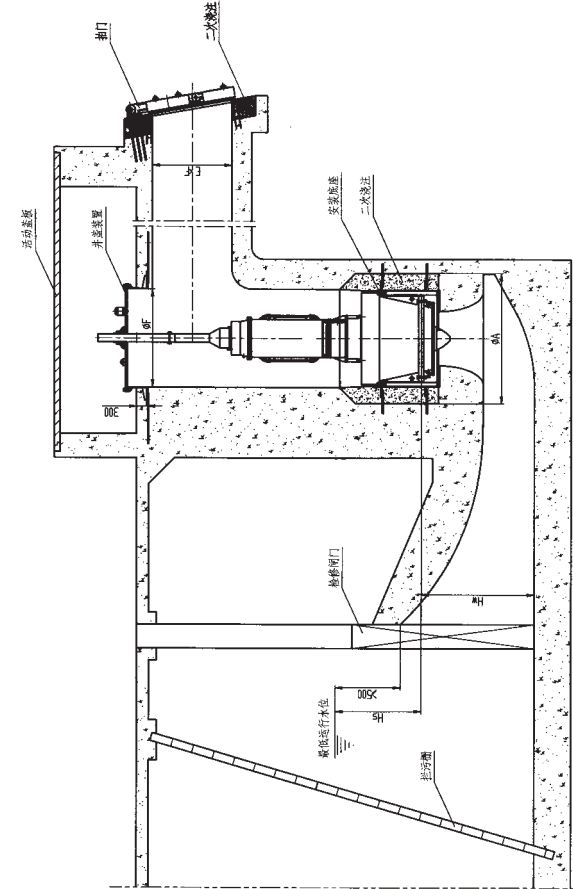

封闭进水流道的混凝土预制井筒式安装尺寸表

Installation dimension table of concrete prefabricated well bore with closed inlet channel

序号 No.	型号 Model	Hw	Hs	øF	øA	E×F	轴向水推力 Axial hydra thrust (N)
1	1200QH-50	1580	2080	1600	1900	1400×1400	94100
2	1200QZ-70		2540				77800
3	1200QZ-100		2620				63000
4	1200QZ-130		2830				54700
5	1200QZ-160		2910				38400
6	1400QZ-70	1990	2640	1900	2200	1400×1800	113000
7	1400QZ-100		2720				91500
8	1400QZ-130		2930				79400
9	1400QZ-160		3010				55700
10	1600QZ-70	2460	2740	2300	2600	1400×1800	166200
11	1600QZ-100		2820				134500
12	1600QZ-130		3030				116800
13	1600QZ-160		3110				81900
14	1800QZ-70	2930	2840	2800	2900	2200×2200	216000
15	1800QZ-100		2920				184500
16	1800QZ-130		3130				166800
17	1800QZ-160		3200				132000
18	2000QZ-70	3370	3265	3220	3335	2500×2500	248400
19	2000QZ-100		3360				212175
20	2000QZ-130		3600				191820
21	2000QZ-160		3680				151800
22	2400QZ-70	3960	3835	3780	3915	3000×3000	291600
23	2400QZ-100		3840				249075
24	2400QZ-130		4225				225180
25	2400QZ-160		4320				178200

选型须知 Instructions for model selection

1、在选型时，应注明泵的型号、安装方式、池深、使用电压及泵控制保护方式，以便提供最优秀的系统。

When selecting the pump, the pump model, installation method, tank depth, operating voltage and pump control and protection method shall be indicated so as to provide the best system.

2、控制柜应注明其起动方式、液压控制方式、安装形式。

The control cabinet shall be indicated with starting mode, hydraulic control mode and installation mode.

3、如需配端子箱，应注明控制型，还是接线型。

The type of terminal box (if required) should be indicated (control type/wiring type).

4、本公司潜水泵潜水电缆正常供货长度为10m，若有特殊要求，请予注明。

The normal supply length of submersible pump cable of our company is 10m. Any special requirements shall be indicated.